



BANGLADESH WATER DEVELOPMENT BOARD

STANDARD SCHEDULE OF RATES MANUAL

VOLUME-I ITEM DESCRIPTION AND SPECIFICATION OF MATERIALS

July, 2018

**DESIGN CIRCLE-II, BWDB
72, GREEN ROAD, DHAKA.**

Preface

The standard schedule of rates manual was prepared by the standard schedule of rates committee constituted vide Board's order No. 216-BWDB (Sectt.)/O&M-1/single-41/91 dated 6th June, 1992. Basis for preparation of this schedule of Rates Manual is a computerized database management system written in dBASE IV programming language which also uses the dBASE utility R&R, prepared by O&M Cost Cell, BWDB under Small Scale Water Control Structure-III Project, sponsored by the Canadian International Development Agency (CIDA). The Standard Schedule of Rates Manual prepared by the committee on computerized database system was approved by the Board vide its order No. 260-WDB/Sectt./O&M-1/single-41/91, dated 18-07-1993 and was implemented through Superintending Engineer, Design Circle-II, BWDB, Dhaka's No. 503 Ka-9/79 dated 22-07-1993. Computerized database management system has been updated from dBASE IV to Microsoft Access with visual basic programming language. Subsequently the manual updates time to time to accommodate new items as per field and design requirement.



(Md. Harun Ur Rasheed)
Superintending Engineer
Design Circle-2, BWDB, Dhaka

TABLE OF CONTENT

	ITEM DESCRIPTION	PAGE NO.
04	Preliminary and Misc. Works	1
08	Carriage.....	5
12	Dewatering	7
16	Earth Work.....	10
20	Brick Work.....	20
24	Plastering Work.....	22
26	Admixture	24
28	Concrete Construction	29
36	Form Work.....	33
40	Protective Work.....	36
44	Piling and Caisson Sinking	63
48	Turfing and Tree Planting.....	69
52	Dismantling and Repair Work	71
56	Road Construction	73
60	Drain Construction	78
64	Building Construction.....	82
68	Wood Work.....	89
72	Painting Work	95
76	M.S. Work & Metal Work.....	98
80	Plumbing Work	106
84	Electriccal Work.....	117
90	Dredging Work.....	129

General Conditions

1. This Standard Schedule of Rates Manual (Volume 1 & 2) has been prepared in compliance with the “BWDB Standard Templates”, approved by the Board vide Memo No. 260-BWDB/Sectt./O&M-1/AKK-41/91, Dated: 18/07/1993 using computer software which is installed in Design Circle-2, BWDB, Dhaka. Subsequent updates and inclusion of new items are also included in this Manual.
2. The Standard Schedule of Rates Manual, Volume 1 contains the “item description” which are common for all BWDB Circle. The Standard Schedule of Rates Manual, Volume 2 contains the “rates” which are prepared on the basis of rate, communicated by the Superintending Engineer, of respective BWDB O & M Circle.
3. While preparing this document, efforts were made to draw a comparison of all individual element rates of different circles and some inconsistencies were noticed in the previously existing rates and the proposed rates of the elements. A committee comprising five members of this office, however, examined rates of elements in the local market. Considering the existing element rates and result of verification of the individual element rates, a realistic judgment has been made in formulating this document. Additionally, efforts were also made to examine element rates of other government departments performing implementation works of nature similar to that of the BWDB.
4. Under the purview of the provisions of the PPR 2008, this document (rates) after due approval is to be used to prepare an official estimate of a particular procurement for which there must be administrative approval and budget allocation. This document (rates) was prepared taking into consideration of unit rates of all elements needed to accomplish the work(s). The construction workers are also direct beneficiaries of the works procured through public fund. It is a well-publicized policy of the government to reduce poverty of the poorest of the poor. People who sell labour for construction works belong to this poor class of the society and due to lack of environment and circumstances; they are not possibly in any good position to bargain with their employers for the just wage.

Thus, it is implied that the Procuring Entity should exercise legitimate authority in the whole process of procurement to safeguard rightful interest of the construction work force.

5. Examining the elements' rates of different Circles, it was noticed that enhancement of rates of all the previously existing rates were proposed by some offices; but in reality with the expansion of trade, industry, manufacturing techniques and improvement of elements' quality, rates of some elements even may be reduced in the market. In the interest of further improvement of this document in the future, it is suggested to prepare a Committee under all the Executive Engineers of the Circle to collect/verify element rates in the market/locality for a significant period and giving due consideration to the prevailing market price and making comparison of elements rates so collected, the elements' rates for the Circle should be recommended in the future.
6. All unit rates are inclusive of carriage of all materials and have been worked out so as to cover the full compensation of materials, labour, equipment and machinery, tools and plants, overhead/incidental charges, etc., necessary to complete the work in all respect required under the respective item. The unit rates are also inclusive of all duties and taxes and a certain amount of profit for the contractors/suppliers. In the relevant cases, it has further taken into account the testing, installation and maintenance expenses. However, in a few cases, the costs for some of the major construction materials have been itemized separately. For example, the cost of reinforcement has been taken out from the item on Reinforced Cement Concrete (R.C.C.) and shown separately.
7. All items of works, contained in the Schedule of Rates, Volume-I, have been described in a precise manner. The Tender Documents should accompany Technical Specifications detailing all procedures in addition to the short description of the Cost Estimates/BOQ and the features shown in the Drawings.
8. Departmental supply of new construction materials is discouraged as restricted under the prevailing Government Rules. However, some specific materials becoming scarce in the country occasionally necessitate their departmental supply. Such provisions, if any, may be kept in the Tender Documents as an exception on due approval of the competent authority clearly stating the corresponding price(s) for cost recovery.

The delivery rate(s) for such materials(s) should correlate the exact amount as considered against them in the Analysis of Rates. All costs of departmentally supplied material(s), if any, shall be recovered from the Contractor(s) at this (these) rate(s) for the entire supply.

9. For the purpose of preparation of estimates in the cases where old materials would be re-used/re-cycled, the damages should be assessed and grouped according to their extent. Such assessment should only be made on undertaking appropriate field survey works through authorized personnel and due verification. Proper methodology should be followed to assess the expected quantity of salvaged materials.
10. For the purpose of recording the quantity of the salvaged materials and to determine and specify their useable quantities, the old materials should be taken out, properly stacked, accurately measured and the measurements are entered in the Measurement Book (MB). The materials should be stacked in a manner that will allow for the Engineer-in-charge to hold random inspection and verification with regard to the quality and the quantity of materials as salvaged. The Engineer-in-charge shall certify the salvaged materials according to his inspection results. Inventory of the materials shall then only be made and the material(s) be allowed for use in the work(s). The Contractor shall agree with the quantity of material(s) salvaged and so certified by the Engineer-in-charge. The material(s) shall, under no circumstance, be issued to the Contractor(s) before the measurement(s) has (have) been properly entered into the permanent record. The value of the material(s), so supplied, shall be recovered from the Contractor strictly in accordance with the provisions of the contract. In case the salvaged materials become more than the quantity shown in the Tender Document/BOQ, the value of the material(s), in excess to the provisions of the Tender Document/BOQ, shall also be recovered.
11. For any quantities of loss or pilferage of the departmentally supplied or the salvaged material(s), the cost shall be recovered from the Contractor(s) at double the delivery rate of the materials(s) specified in the Tender Document. The Contractor(s) is (are) also required to return to the Department any quantity of material that may remain unused from the supply given by the Department or salvaged.

12. Unless provisions are made in the Technical Specifications, every item of this Schedule of Rates shall also comprise activities like mobilization, de-mobilization and clearance of work site. Separate item should not be provided for these activities in the estimate/BOQ unless an exception is allowed by the authority. In the case of any exception, obtaining prior approval of the authority shall be compulsory.
13. The Contractor(s) at his (their) own cost shall perform all laboratory tests required for the construction works in the BWDB authorized laboratories/facilities established at the site (if any). The testing facilities if not available with the BWDB, may be performed outsource as directed by the Superintending Engineer. The Superintending Engineer/Executive Engineer shall reserve the right to increase the frequency of testing on actual requirement.
14. All unit rates contained in this Schedule of Rates are inclusive of all duties and taxes as required under the law of the country and the Contractor(s) shall remain liable to pay them all. The Contractor(s) shall include all these levies in his (their) tender prices for all items of works and no additional claim for payment of taxes and duties or any compensation to subsequent increase in the existing taxes, duties, etc. shall be entertained by the authority. The Income Tax and VAT shall be deducted at source strictly in accordance with the rules of the NBR and shall be credited immediately to the respective head of account of the Government as per BWDB's standing orders.
15. In case of detection of any error or omission in the specifications during or prior to implementation of work, it should immediately be brought to the notice of the authority for necessary correction or amendment.
16. The Executive Engineer of the Division is the key-person for overall management and supervision of works supported by the Sub-Divisional Engineer/Assistant Engineer and the Sub-Assistant Engineers (SAEs). It is their responsibility to ensure that the items of this Schedule of Rates are strictly implemented in the work(s) with all stipulations, specifications and details. Standard field/laboratory tests are to be performed with random sampling of brick, cement, sand, M.S. bar and other principal construction materials. Random cylinder/cube tests for Cement Concrete shall be

carried out at the specified frequency for all concrete structural elements in order to protect their requisite strength.

17. Estimates of dewatering operation, closure dam and dredging work shall be send to the Design Circle-2 for vetting prior to inclusion in the estimate/BOQ.
18. Estimate/BOQ for earth work shall be prepared on pre-work and post-work basis and the same will be checked as per codal rule by the respective authorized officers. On issuing detail work order, the BOQ for earth work shall be checked by the contractor(s) at own expense/arrangement and inform the outcome in a written letter to the Executive Engineer. Variation from the sanctioned estimate, if any, must be reported to the Superintending Engineer for verification and clearance by him.
19. The rates in the “Schedule of Rates” are for finished item of works unless otherwise explicitly mentioned and include all the cost incidental to the items.
20. Every item of the Schedule is to be executed unless otherwise specified as per Standard Specifications of the BWDB.
21. Elements rates where applicable are exclusive of the containers; for example the rate of cement, bitumen etc. are exclusive of the cost of empty bags, drums etc. respectively except for the imported items unless otherwise mentioned.
22. Rates for all works are inclusive of the lighting, guarding and putting barrier/fencing etc. during execution of works.
23. All tools, plants and articles, and equipment needed for the execution of the works are to be supplied by the contractor at his own cost unless otherwise specified. Provision of such cost has been made in the Schedule of Rates. In case of hiring the Departmental equipment, the contractor will have to pay the Departmental hire charge at the rate(s) specified by the BWDB.
24. Removal includes cost for removal of old materials from the site where necessary.
25. Earth work for payment will be calculated from *pre-work* and *post-work* sections of work in the construction of new embankment, re-sectioning of old embankment,

excavation & re-excavation of canal and dredging works (excluding small repair, if any).

26. In determining the Formation Level of a compacted embankment, 10% (ten percent) of the fill height calculated on the basis of Pre-work Level and Design Level shall be added to Design Level while preparing official estimate. But post-work measurement shall be precisely as per the work done status.
27. Leads and lifts shall be reckoned from the centre of excavated sections to the centre of the place of throwing the spoil. Measurement for lead(s) and lift(s) shall be based on unit of shortest distance traversed and part of units shall be counted for full unit measurement subject to the conditions that fraction of 30 (thirty) cm over the unit of lift and fraction of 3 m (three) meter over the unit of lead shall not be considered for a full unit.
28. Local carriage within 300 meter of the work site is included in the item rates of works.
29. Unless otherwise specified, cost of scaffolding is included in the rates of such item of work requiring the scaffolding.
30. Members of formwork of timber shall be local hard wood of approved quality or as specified in the description. All formwork shall be rigidly constructed and must not sway under working load on vibration of the construction machinery and equipment.
31. Cost of all kinds of testing of material properties as and when desired by the Executive Engineer shall be considered to be included in the unit price. No extra cost on account of testing materials to be used in work shall be admissible unless otherwise specified.
32. Concrete works shall mean providing standard joints in every sequence of construction including cleaning, removing loose mortars, brushing, pouring cement paste between the grey and green concrete etc. for which no extra cost shall be admissible unless otherwise specified.

33. Cement concrete blocks shall generally be provided with one number (25mm dia.X 25mm deep) curing water trap on the top-centre unless otherwise specified.
34. In manufacturing cement concrete blocks, the platform shall be made by one brick flat soling and polythene sheet (1.0 kg. per 16.0 sqm) shall be used for preventing leakage through bottom face of the shutter.
35. Load test of form work for massive concrete work, if any, shall be carried out with written permission from the project authority in consultation with the concerned Design Office before tendering.
36. In all hydraulic structures steel shuttering shall only be used except minor ones as permitted in the tender, if any.
37. In concreting the pre-cast R.C.C piles, polythene sheet shall be used at the bottom and on the two sides.
38. Rates for sand and cement plastering, pointing etc. includes raking out joints of bricks and clearing the surface of the wall or face of the member.
39. Rates for white washing, colour washing and painting include the cost of removal of old white wash, rusts and paint marks by scraping or iron brushing from the wall surface, chowkats, glass panels, metals etc.
40. One face of the opening shall be measured for payment for plastering and white washing to compensate for jams, sills and soffits of doors and windows.
41. Diameter of Wooden Bullah will be measured at a distance $\frac{1}{3}$ (one third) length from butt end without bark.
42. In the measurement of the volume of Boulders and Gravels, percent deduction for void shall be made at the specified rates mentioned against the respective item to account for void.
43. In repair works, the pavement shall be made for the actual requirement of repair only to bring the work back similar to the original state/condition.

44. All kinds of R.C.C pipes and sockets shall be manufactured in close conformity with the AASHTO Designation (M 170M-89).
45. The weight of Geo-bag has been considered on the basis of dry unit of sand in this schedule.
46. Cost of stacking of CC block, Boulders, Hard Rock, Geo-bag etc. was included in the respective item.
47. Cost of survey required during dredging work has been included in the respective dredging Item.
48. Item code and sub-item code against each item description marked in the Standard Schedule of Rates must be quoted in preparing estimate of a work and the work Schedule/BOQ for a tender.
49. In preparing an estimate of work, item of works listed under different Chapters may be combined. But it should be carefully noted that the item of works, which are earmarked for a particular kind of work, must not be applied for a work of different nature.
50. No additional item of work and element description shall be inserted or no existing item of work and element description shall be altered or deleted in this Standard Schedule of Rates Manual without vetting by Design Circle-2, BWDB, Dhaka.



(Md. Harun Ur Rasheed)
Superintending Engineer
Design Circle-2, BWDB, Dhaka

ITEM DESCRIPTION REPORT

The item Description Report provides general element quantity and quality specification. An item code, description and unit of measure are defined for each work item. The item code is a unique and permanent number assigned to each item for sorting purpose. Item codes are defined by a five digit number, and sub items are defined by a seven digit number. The item description stipulates the work requirements: the scope of work, materials to be used, and procedures to be followed. The unit of measure specifies how the work item volume is to be assessed.

The Standard Rates Committee of BWDB reviewed the Standard Schedule of Rates System prepared by O&M cost cell in October, 1991, and the present schedule of rates Manual is prepared on the basis of program developed by O&M cost cell. Some new item has been enclosed as per present need.

The item prepared by O&M cost cell were based almost exclusively on existing BWDB documents. The O&M cost cell reviewed current BWDB circle schedule of rates and selected appropriate descriptions as per their judgment.

In reviewing the descriptions and analysis of items of rates incorporated in the Standard Schedule of Rates System developed by O&M cost cell, it was observed that a big majority of the descriptions of items of works were not clear, some of the items were found to be superfluous and some relevant items were missing. So to cope with the requirement of BWDB, items of works were edited, deleted and appended in the light of existing schedule of rates of BWDB, PWD, RHD and E & M Circle of PWD.

The items included in primary item classification Codes were also re-arranged without any changed in primary classification Code, set by O&M Cost Cell.

Item Description Report

ITEM DEFINITION REPORT

ItemCode	Item Description	Unit Meas.
04 . Preliminary & Misc. Work		
04-100	Manufacturing and supplying R.C.C. boundary pillar, bench mark pillar and kilometer post in proportion 1:2:4, as per approved drawing and specifications, 110cm height, bottom dia 25cm and top dia 20cm, of which 15cm slanting and 5cm level; with 6 nos. 10mm dia vertical rod and 8 nos. 6mm dia binder excluding the cost of M.S. works for reinforcement but including the cost of form works, plastering top, finishing surface, curing with inscription of "BWDB, R.L./K.M." mark, as per approved size and shape in exposed surface etc. complete, as per direction of Engineer in charge.	each
04-110	Fixing in position, boundary pillars/bench mark pillars/K.M. post etc. of size 110cm height, bottom dia 25cm and top dia 20cm, embedded 45cm below G.L. including carriage, earth cutting, filling, ramming, etc. complete as per direction of Engineer in charge.	each
04-120	Construction of B.M. Pillars at site with first class bricks in cement mortar (1:4) of size 38cmx38cmx75cm on cement concrete (1:2:4) base of size 50cmx50cmx7.5cm with 12mm thick cement plastering (1:2) on exposed surfaces of pillar and cement mortar on top (1:2), with inscription of "BWDB" with 25cm of the pillar below ground level etc. complete including ramming the backfill and the cost of all materials as per direction of Engineer in charge.	each
04-130	Manufacturing and supplying R.C.C. (1:2:4) boundary pillar triangular in shape 20cm sides, 75cm height and 40cmx40cmx10cm base, with 3 nos 10mm dia bar each way at base, 3 nos 10mm dia vertical bar & 8 nos. 6mm dia rings, excluding the cost of M.S. works for reinforcement but including the cost of form works,plastering top, finishing surface, curing with inscription of "BWDB" on exposed surface etc. complete as per direction of Engineer in charge.	each
04-140	Fixing in position triangular boundary pillar of 20cm sides, 75cm height with 40cmx40cmx10cm base, embedded 45cm below G.L. including carriage, earth cutting, backfilling, ramming etc. complete as per direction of Engineer in charge.	each
04-150	Manufacturing and supplying R.C.C. (1:2:4) B.M. Pillars of size 15cmx15cmx75cm, with 40cmx40cmx10cm base having 3 nos. 10mm dia M.S.bar each way at base, 4 nos. 10mm dia vertical bar and 8 nos. 6mm dia ring, excluding cost of M.S. works for reinforcement but including cost of form works, concreting, plastering at top, finishing surface, curing etc. complete, with inscription of "BWDB", on exposed surface etc. complete as per direction of Engineer in charge.	each
04-160	Fixing in position B.M. pillars and kilometer posts of size 15cmx15cmx75cm with 40cmx40cmx10cm base, embedding 45cm below G.L. including carriage, earth cutting, backfilling, ramming, etc. complete as per direction of Engineer in charge.	each

ITEM DEFINITION REPORT

ItemCode	Item Description	Unit Meas.
04-180	Site preparation by manually removing all miscellaneous objectional materials from entire site and removing soil upto 15cm depth including uprooting stumps, jungle clearing, levelling dressing etc. complete as per direction of Engineer in charge.	sqm
04-200	Supplying & fixing at site temporary bamboo gauges, 6cm to 9cm dia, marked in meter, decimeter and centimeter, including black & white water proof painting and printing gauge, to be driven not less than 1.80m below ground (Measurement will be given only for the marked portion) as per direction of Engineer in charge.	m
04-210	Supplying & fixing wooden gauges at site, made of sal/gajari/sundari wood, engraved in meter, decimeter & centimeter, including water proof painting with black, white & red paint, etc. complete as per direction of Engineer in charge.	m
04-210-10	150mm x 25mm, size (finished section).	m
04-210-20	100mm x 25mm, size (finished section).	m
04-230	Supplying & fixing at site triangular gauges of 15 cm size made of best quality local hard wood, engraved in meter, decimeter & centimeter, including water proof painting with black, white & red paint, etc. complete as per direction of Engineer in charge.	m
04-240	Supplying & driving 2.8m long, 15 cm to 20 cm average dia local hard wood post of approved quality, including sizing, sharpening & providing holes for fitting gauges (driving portion not less than 1.80 m) etc. complete as per direction of Engineer in charge.	each
04-260	Fixing gauges to posts including supply of necessary bolts and nuts or nails.	each
04-280	Constructing at site, cement mortar gauge on masonry wall, including engraving in meter, decimeter & centimeter, painting and figuring with black and red water proof paint, etc. complete as per direction of Engineer in charge.	m
04-280-10	150mm x 25mm	m
04-280-20	100mm x 25mm	m
04-290	Repairing of cement concrete gauge including plastering, painting, lettering etc. complete as per direction of Engineer in charge.	m
04-310	Supplying 7.50 cm dia bamboo sounding rods, 450 cm long, with black & white paint, at every alternative decimeter and figuring etc. complete as per direction of Engineer in charge.	each
04-320	Supplying bamboo pegs 0.45 m to 0.75 m long and average dia 6 cm, with saw cut top as per direction of Engineer in charge.	no
04-330	Labour charge for fixing the bamboo pegs 0.45m to 0.75m long and average dia 6cm, as per direction of Engineer in charge.	no

ITEM DEFINITION REPORT

ItemCode	Item Description	Unit Meas.
04-400	Removing water hyacinth and stacking on the bank and burning in to ashes:	sqm
04-400-10	scattered	sqm
04-400-20	packed	sqm
04-410	Cutting trees and uprooting stumps and removing the same from the base of embankment and keeping in a place, as per direction of Engineer in charge.	each
04-410-10	30 cm to 1.0 m girth	each
04-410-20	1.0 m to 1.50 m girth	each
04-410-30	above 1.50 m girth	each
04-440	Cutting and clearing jungles and uprooting trees upto 30cm girth and removing the same from the site as per direction of Engineer in charge.	sqm
04-440-10	ordinary	sqm
04-440-20	thick and thorny	sqm
04-450	Cutting, uprooting and removing bamboo cluster from the site as per direction of Engineer in charge.	sqm
04-460	Cutting, uprooting and removing cane jungles, from the site, as per direction of Engineer in charge.	sqm
04-470	Supplying cross section nylon ropes, marked at every decimeter:	m
04-470-10	6mm dia	m
04-470-20	12mm dia	m
04-490	Jafry bamboo fencing with 75mm x 75mm gap with bamboo posts 60mm to 80mm dia, at 1.20m apart including fitting, fixing complete by bamboo battens at 30cm apart both ways.	sqm
04-500	Supplying, fitting and fixing bamboo fencing 1.0mx1.0m, around the gauge with split bamboo walling pieces (minimum width 40mm) @ 20cm c/c, including fixing with necessary bamboo posts, by nails etc. complete (average dia of bamboo 75mm), as per direction of Engineer in charge.	each
04-510	Providing barbed wire fencing with average 100mm dia best quality local ballah post of 2.20m total height, (1.6m above G.L., and 60cm embedded in the ground) placed at 1.8m c/c with 9 nos. horizontal lines and 2 nos diagonal lines of 12 BWG 2 ply barbed wire with 4 points barbs at 100 mm c/c, including digging holes and embedding the post properly in ground, stretching the wire and fixing with the post with minimum 62mm long G.I. nails including supply of all materials, etc. complete as per direction of Engineer in charge.	m

ITEM DEFINITION REPORT

ItemCode	Item Description	Unit Meas.
04-520	Supplying, fitting and fixing 12 BWG barbed wire (2 ply, 4 points; 100mm apart) in fencing work @ 150mm c/c both horizontally and vertically supported by 38mmx38mmx6mm M.S. angle post (300mm embedded in R.C.C. or in B/W, 600mm vertical and 450mm inclined or as per requirement) @ 2.4m c/c including strengthening, tightening, binding the joints with 18 BWG wire making holes in the angle including supply of all necessary materials and making good of damages caused to RCC/ brick work etc. complete as per direction of Engineer in charge.	sqm
04-530	Supplying , fitting and fixing 12 BWG galvanised barbed wire fencing (single line) with 2 ply wire, 4 points 100mm apart, fitted with balli posts/ angle posts etc. with necessary nails/ G.I. wire (2 ply 16 BWG) etc. complete as per direction of Engineer in charge (excluding the cost of posts).	m
04-600	Providing cork sheet/polysterene sheet in expansion joints of concrete works including supply of all materials etc. complete as per direction of Engineer in charge.	sqm
04-600-10	25 mm thick sheet.	sqm
04-600-20	20 mm thick sheet.	sqm
04-620	Filling of expansion joints upto a depth of 40 mm with bitumen mixed with coarse sand (FM \geq 2.5) in concrete works including supply of all materials etc. complete as per specification and direction of Engineer in charge.	m
04-620-10	25 mm wide.	m
04-620-20	20 mm wide.	m

ITEM DEFINITION REPORT

ItemCode	Item Description	Unit Meas.
08 . Carriage		
08-100	Carriage of materials by head load including stacking in measurable stacks properly as per direction of Engineer in charge.	pmt/m
08-100-10	0.00 m to 50.00 m.	pmt/m
08-100-20	0.00 m to 100.00 m.	pmt/m
08-100-30	0.00 m to 250.00 m.	pmt/m
08-100-40	0.00 m to 750.00 m.	pmt/m
08-110	Carriage of materials by cart in all types of road, including loading, unloading and stacking in measurable stacks properly for every subsequent kilometer or part thereof (less than 0.25 km to be neglected) as per direction of Engineer in charge.	pmt/km
08-110-10	Within 1.00 km.	pmt/km
08-110-20	2nd km and above.	pmt/km
08-120	Carriage of materials by boat including loading, unloading and stacking in measurable stacks properly for every subsequent kilometer or part thereof (less than 0.25 km to be neglected) as per direction of Engineer in charge.	pmt/km
08-120-10	By boat : within 1.00 km.	pmt/km
08-120-20	By boat : 2nd km. and above.	pmt/km
08-130	Carriage of cement, C.I. sheet, bitumen, M.S. rod, sheet pile of minimum 6.0m length etc. by truck in all types road, including loading, unloading and stacking in measurable stacks properly for every subsequent kilometer or part thereof (less than 0.25 km to be neglected) as per direction of Engineer in charge.	pmt/km
08-130-10	Within 1.00 km.	pmt/km
08-130-20	2nd km and above.	pmt/km
08-140	Carriage of sand, brickbats, shingles, boulders, c.c block, geo-bag, coal, timber etc. by head load including stacking in measurable stacks etc. complete (no carriage for 15m or part thereof) as per direction of Engineer in charge.	pcum/m
08-140-10	0.00 to 50.00 m.	pcum/m
08-140-20	0.00 to 100.00 m.	pcum/m
08-140-30	0.00 to 250.00 m.	pcum/m
08-140-40	0.00 to 750.00 m.	pcum/m

ITEM DEFINITION REPORT

ItemCode	Item Description	Unit Meas.
08-150	Carriage of sand, brick bats, shingles, boulders, c.c block, geo-bag, coal, wood etc. from different field/ departmental stocks to work sites by truck/ boat/ cart including carriage by head load upto a distance of 30m at each point including loading, unloading and stacking at work site in measureable stacks (less than 0.25m neglected) as per direction of Engineer in charge.	cum/km
08-150-10	By cart : Within 1.00 km.	cum/km
08-150-20	By cart : 2nd km and above.	cum/km
08-150-30	By boat : within 1.00 km.	cum/km
08-150-40	By boat : 2nd km. and above.	cum/km
08-150-50	By truck : within 1.00 km.	cum/km
08-150-60	By truck : 2nd km. and above.	cum/km
08-180	Carriage of bricks (1000 nos) from one place to another by head load including stacking in measurable stacks etc. complete (no carriage for 15m or part thereof) as per direction of Engineer in charge.	per m
08-180-10	0.00 to 50.00 m.	p%0/m
08-180-20	0.00 to 100.00 m.	p%0/m
08-180-30	0.00 to 250.00 m.	p%0/m
08-180-40	0.00 to 750.00 m.	p%0/m
08-190	Carriage of bricks (1000 nos) from one place to another including loading and unloading involving carriage by head load to a distance of 30 m at each loading and unloading point including stacking properly in measurable stacks etc. complete (less than 0.25 km be neglected) as per direction of Engineer in charge.	p%0/km
08-190-10	By cart : Within 1.00 km.	p%0/km
08-190-20	By cart : 2nd km and above.	p%0/km
08-190-30	By boat : within 1.00km.	p%0/km
08-190-40	By boat : 2nd km. and above.	p%0/km
08-190-50	By truck : within 1.00km.	p%0/km
08-190-60	By truck : 2nd km. and above.	p%0/km

ITEM DEFINITION REPORT

ItemCode	Item Description	Unit Meas.
12 . Dewatering		
12-100	Installation of pizeometer including supply of 40mm G.I. pipe, brass strainer, socket, labour, by wash boring, lowering, fixing the elevation and providing cover on the top of the well etc. complete as per direction of Engineer in charge.	each
12-110	Mobilization of complete well point system, equipments and accessories from one place to another including loading and unloading as per direction of Engineer in charge.	ps/km
12-110-10	Within 1.00 km.	ps/km
12-110-20	2nd km. and above.	ps/km
12-120	Installation of well point dewatering set including supply of all accessories, materials and labours for one 5 cusec vacuum pump for minimum 100 well points in controlling subsurface water during construction, providing shrouding materials, conducting test operation and subsequent removal of the complete dewatering set in accordance with standard specification and field requirement, as per direction of Engineer in charge.	set
12-150	Operation of well point system, by 5 cusec vacuum pump for dewatering of subsurface water, maintaining draw down records including supply of necessary fuels, lubricants, operation personnel and maintenance of the same upto completion of the work in accordance with standard specification and direction of Engineer in charge.	pphour
12-160	Demobilization of complete well point system, equipments and accessories from one place to another including loading and unloading as per direction of Engineer in charge.	ps/km
12-160-10	Within 1.00 km.	ps/km
12-160-20	2nd km. and above.	ps/km
12-180	Installation of dewatering tubewells at site for controlling subsurface water during construction, including supply of all materials, equipments, fuels, lubricants etc. providing shrouding materials, conducting well testing & development and subsequent removal of complete dewatering system in accordance with standard specification and field requirement etc. complete including sealing of hole, mobilization and demobilization of equipments and accessories (contractor has to prepare and submit a dewatering plan based on field requirement to the competent authority for approval, prior to installation of the tube well) as pe direction of Engineer in charge.	ptwell
12-180-05	12.0m depth including strainer (as per design) and 75mm dia tubewell (bore hole 200mm dia) with PVC pipe and strainer.	ptwell
12-180-10	18.0m depth including strainer (as per design) and 75mm dia tubewell (bore hole 200mm dia) with PVC pipe and strainer.	ptwell

ITEM DEFINITION REPORT

ItemCode	Item Description	Unit Meas.
12-180-15	12m depth including strainer (as per design) and 100mm dia tubewell (bore hole 250mm dia) with PVC pipe and strainer.	ptwell
12-180-20	18m depth including strainer (as per design) and 100mm dia tubewell (bore hole 250mm dia) with PVC pipe and strainer.	ptwell
12-180-25	18m depth including strainer (as per design) and 150mm dia tubewell (bore hole dia 300mm dia) with PVC pipe and strainer.	ptwell
12-180-30	24m depth including strainer (as per design) and 150mm dia tubewell (bore hole dia 300mm dia) with PVC pipe and strainer.	ptwell
12-180-35	30m depth including strainer (as per design) and 150mm dia tubewell (bore hole dia 300mm dia) with PVC pipe and strainer.	ptwell
12-180-40	18m depth including strainer (as per design) and 150mm dia tubewell (housing pipe 300mm dia and bowel assembly) with GI pipe and brass strainer.	ptwell
12-180-45	24m depth including strainer (as per design) and 150mm dia tubewell (housing pipe 300mm dia and bowel assembly) with GI pipe and brass strainer.	ptwell
12-180-50	30m depth including strainer (as per design) and 150mm dia tubewell (housing pipe 300mm dia and bowel assembly) with GI pipe and brass strainer.	ptwell
12-180-55	18m depth including strainer (as per design) and 200mm dia tubewell (housing pipe 350mm dia and bowel assembly) with GI pipe and brass strainer.	ptwell
12-180-60	24m depth including strainer (as per design) and 200mm dia tubewell (housing pipe 350mm dia and bowel assembly) with GI pipe and brass strainer.	ptwell
12-180-65	30m depth including strainer (as per design) and 200mm dia tubewell (housing pipe 350mm dia and bowel assembly) with GI pipe and brass strainer.	ptwell
12-200	Operation of tubewell by centrifugal pump for dewatering of subsurface water, maintaining drawdown records including supply of necessary fuels, lubricants, operation personnel and maintenance of the same upto the completion of the work as per specification and direction of Engineer in charge.	pphour
12-200-10	0.75 cusec capacity	pphour
12-200-20	0.50 cusec capacity	pphour
12-210	Operation of tubewell by 2 cusec turbine pump for dewatering of subsurface water, maintaining drawdown records including supply of necessary fuels, lubricants, operation personnel and maintenance of the same upto the completion of the work as per specification and direction of Engineer in charge.	pphour
12-210-10	For 18m depth of tubewell : Electric Motor, 20 HP with 2 cusec pump.	pphour
12-210-20	For 24m depth of tubewell : Electric Motor, 25 HP with 2 cusec pump.	pphour
12-210-30	For 30m depth of tubewell : Electric Motor, 30 HP with 2 cusec pump.	pphour

ITEM DEFINITION REPORT

ItemCode	Item Description	Unit Meas.
12-250	Installation of Booster Pump for major structure (5 cusec Turbine Pump with Motor and all other accessories) at suitable elevation within area to be dewatered including construction of masonry sump of 2.5mx2.5mx3.0m, connecting the delivery pipes of the wells, mounting the pumps and motors, laying in position the high head delivery pipes upto discharge outlet including staging, electric connections and test operations etc. complete as per approved dewatering plan and direction of Engineer in charge.	each
12-260	Operation of Booster Pump for dewatering of subsurface water, including supply of necessary fuels, lubricants, operation personnel and maintenance of the same upto completion of the work as per standard specification and direction of Engineer in charge.	pphour
12-300	Construction of sump well with dug holes of size 1.80 m x 2.0 m, laying in position the perforated empty diesel/petrol drum sheet of 1.00 m dia to a depth 1.5m having slot area of 1000 sq.cm/sqm, slot dia being 30mm each with supply of necessary shrouding materials comprising of 60% 40mm down graded khoa and 40% coarse sand of FM \geq 2.50 and placing those around and beneath the drum sheet having thickness of 40cm and 50cm respectively including necessary welding, fitting etc. complete as per direction of Engineer in charge.	each
12-310	Bailing out of water with all leads and lifts by manual labour or pump, with all arrangements for protection of ring bund and side slopes of foundation pit against erosion or washout etc. complete actual volume of work will be measured by sounding method before starting the work) as per direction of Engineer in charge.	cum
12-310-10	by manual labour.	cum
12-310-20	by pump.	cum

ITEM DEFINITION REPORT

ItemCode	Item Description	Unit Meas.
16 . Earthwork		
16-100	Erection of bamboo profile with full bamboo posts and pegs not less than 60mm in diameter and coir strings etc. complete as per direction of Engineer in charge.	each
16-110	Earth work by manual labour in constructing/ resectioning of embankment/ canal bank/ road etc. with clayey soil(minimum 30% clay, 0-40% silt and 0-30% sand) within the initial lead of 30m, and all lifts including throwing the spoils to profiles in layers not exceeding 150mm in thickness, clod breaking upto a maximum size of 100mm, benching the side slopes, stripping/ ploughing the base of embankment and borrow pit area, dug bailing, cutting trees upto 200mm girth, with uprooting stumps, clearing jungles, bailing out water, rough dressing and 150mm cambering at the centre of the crest etc. complete as per specification and direction of Engineer in charge.	cum
16-110-10	0 to 3 m height.	cum
16-110-20	0 to 4 m height.	cum
16-110-30	0 to 5 m height.	cum
16-110-40	0 to 6 m height.	cum
16-120	Earth work by manual labour in constructing/ resectioning of embankment/ canal bank/ road etc. compacted to 85%/90% maximum dry density at optimum moisture content, with reference to laboratory density test AAHSTO modified hammer, with clayey soil(minm 30% clay, 0-40% silt, 0-30% sand) within the initial lead of 30m and all lifts including throwing the spoils to profiles in layers not exceeding 230mm in thickness with clod breaking to a maximum size of 100mm, benching the side slopes, removing roots and stumps of trees of girth upto 200mm from the ground, stripping/ ploughing the base of embankment and borrow pit area, dug bailing, bail out of water, rough dressing including 150mm cambering at the centre of crest etc. complete, including maintenance of the same for 6 months after completion, (compaction will be done by the contractor with approved equipment, including all ancillary charges for compaction and testing) as per direction of Engineer in charge.	cum
16-120-10	0 m to 3 m height with 85% compaction.	cum
16-120-20	0 m to 4 m height with 85% compaction.	cum
16-120-30	0 m to 5 m height with 85% compaction.	cum
16-120-40	0 m to 6 m height & above with 85% compaction.	cum
16-120-50	0 m to 3 m height with 90% compaction.	cum
16-120-60	0 m to 4 m height with 90% compaction.	cum
16-120-70	0 m to 5 m height with 90% compaction.	cum
16-120-80	0 m to 6 m height & above with 90% compaction.	cum

ITEM DEFINITION REPORT

ItemCode	Item Description	Unit Meas.
16-130	Earth work by manual labour in all kinds of soil in excavation or reexcavation of channels with the initial lead of 30m and lift of 1.5m including levelling, dressing and throwing the spoils to profile with breaking clods, rough dressing, clearing jungles including cutting trees upto 200mm girth, dug bailing etc. complete as per direction of Engineer in charge.	cum
16-140	Earth work by manual labour in resectioning of embankment/ canal bank/ river slopes/ road/ compound etc. manually compacted by 7.0 kg iron rammer to avoid any air pocket in clayey soil (minimum 30% clay, 0-40% silt and 0-30% sand) within the initial lead of 30m and all lifts including throwing the spoils to profile in layers not exceeding 150mm thickness with clod breaking to a maximum size of 100mm, removing roots & stumps of trees of girth upto 200mm from the ground, benching the side slopes, stripping/ ploughing the base of embankment and borrowpit areas, dug bailing, bail out of water, rough dressing including 150mm cambering at the centre of the crest (where necessary) etc. complete as per direction of Engineer in charge.	cum
16-140-10	0 m to 3 m height.	cum
16-140-20	0 m to 4 m height.	cum
16-140-30	0 m to 5 m height.	cum
16-140-40	0 m to 6 m height.	cum
16-150	Earth work in excavation of foundation trenches in all kinds of soils including levelling, dressing, placing, removal of spoils to a safe distance with initial lead of 30m and lift of 1.5m as per direction of Engineer in charge.	cum
16-190	Extra rate for every additional lead of 15m or part thereof beyond the initial lead of 30m upto a maximum of 19 leads (3m neglected) for all kinds of earth work.	pldcum
16-200	Extra rate for every additional lift of 1.0m or part thereof beyond the initial lift of 1.5m (30cm neglected) for all kinds of earth work.	pltcum
16-210	Compaction of earth in constructing/resectioning of embankment/ canal bank/road/river slopes etc. by mechanical equipment to attain 85% / 90% maximum dry density at optimum moisture content with reference to laboratory density test AASTHO-180 modified hammer in all kinds of soils as per direction of Engineer in charge.	cum
16-210-10	0.0m to 6.0m height and above, with 85% compaction.	cum
16-210-20	0.0m to 6.0m height and above, with 90% compaction.	cum
16-220	Earth work by manual labour with clayey soil (minimum 30% clay, 0-40% silt and 0-30% sand) in construction of cross bundh/ ring bundh as per design and specification with all leads and lifts, throwing the earth in layers not exceeding 150mm in thickness, including breaking clods, rough dressing, clearing the jungle, removing stumps, dug bailing and 75mm cambering etc. complete as per direction of Engineer in charge.	cum

ITEM DEFINITION REPORT

ItemCode	Item Description	Unit Meas.
16-230	Compaction of earth in resectioning of embankment/ canal bank/ road/ river bank slopes/ compounds etc as per design to profile in layers not exceeding 150mm in thickness in all kinds of soils etc. complete as per direction of Engineer in charge.	cum
16-230-10	By engine operated vibratory soil compactor to attain 80% maximum dry density at optimum moisture content with reference to laboratory density test AASHTO-180 modified hammer.	cum
16-230-20	By 7.00 kg. iron rammer to remove all voids from soil.	cum
16-240	Earth work by manual labour, in all kinds of soil in removing the cross bundh/ ring bundh, including all leads and lifts complete and placing the spoils to a safe distance, (minimum 15m apart from the bank) as per direction of Engineer in charge.	cum
16-270	Earth work by manual labour with clayey soil (minimum 30% clay, 0-40% silt and 0-30% sand) for closing breach or channel, with all leads and lifts within the channel width including profiling, clod breaking, ramming etc. complete as per specification and direction of Engineer in charge.	cum
16-270-10	Upto 30m width.	cum
16-270-20	Upto 45m width.	cum
16-270-30	Upto 60m width.	cum
16-270-40	Upto 75m width.	cum
16-270-50	Upto 90m width.	cum
16-280	Earth work in closing ghogs or holes in the embankment or banks with clayey soil (minimum 30% clay, 0-40% silt and 0-30% sand) including cutting, filling, watering etc. complete with all leads and lifts (only pit measurement will be allowed) as per direction of Engineer in charge.	cum
16-300	Royalty of specified earth taken from private land (with prior permission of the Executive Engineer on production of royalty deeds with the land owner) from the area to be selected by the contractor with mutual agreement.	cum
16-310	Earth work in excavation of foundation trenches in all kinds of soil as per layout plan of foundation excavation with all leads and lifts and placing the spoil earth for constructing the ring bundh/ cofferdam where necessary as per design and specification or disposing it to a safe distance including pushing, levelling, dressing, etc. complete as per direction of Engineer in charge.	cum
16-310-10	For moving spoil earth upto a distance of 100m from the centre of the pit.	cum
16-310-20	For moving spoil earth upto a distance of 200m from the centre of the pit.	cum
16-310-30	For moving spoil earth upto a distance of 300m and above from the centre of the pit.	cum

ITEM DEFINITION REPORT

ItemCode	Item Description	Unit Meas.
16-330	Earth work in excavation of foundation trench in all kinds of soil as per design and specification, including removing spoils, levelling, dressing ramming etc complete (for building work) as per direction of Engineer in charge.	cum
16-340	Earth work in removal of slushy earth, including all leads and lifts form the bed of the sluices or any other places, in accordance with specification (prior permission from the Executive Engineer has to be taken before execution of the work regarding necessity and quantity of work) as per direction of Engineer in charge.	cum
16-350	Earth work by Carried Earth (by truck/boat or any other means) supplied at contractor's own cost (including royalty) in resectioning of embankment/ canal bank/ river slopes/ road/ compound etc. manually compacted by 7.0 kg iron rammer to avoid any air pocket with clayey soil (minimum 30% clay, 0-40% silt, 0-30% sand) beyond the initial lead of 300m and all lifts including throwing the spoils to profile in layers not exceeding 150mm thickness with clod breaking to a maximum size of 100mm, removing roots & stumps of trees of girth upto 200mm from the ground, benching the side slopes, stripping/ ploughing the base of embankment and borrowpit areas, dug bailing, bail out of water, rough dressing including 150mm cambering at the centre of the crest (where necessary) etc. complete as per direction of Engineer in charge.	cum
16-350-10	300 m to 1.00 km.	cum
16-350-20	1.00 km. to 5.00 km.(Extra rate).	cum
16-360	Earth work by carried earth by truck/boat or any other means supplied at contractor's own cost (including royalty) in constructing/ resectioning of the embankment/ canal bank/ road etc. in clayey soil (minimum 30% clay, 0-40% silt and 0-30% sand) beyond the initial lead of 300m including throwing the spoils to a profile in layers not exceeding 150mm in thickness, breaking clods, benching the side slopes, stripping the base of embankment and borrow pit area, dug bailing, cutting trees upto 200mm girth with uprooting stumps, clearing jungles, bail out of water, rough dressing and 150mm cambering at the centre of the crest etc. complete as per design, specification and direction of Engineer in charge.	cum
16-360-10	300m. to 1.00 km.	cum
16-360-20	1.00 km. to 5.00 km. (Extra rate)	cum
16-370	Earth work by carried earth (by truck/boat or any other means) supplied at contractor's own cost (including royalty) with clayey soil (minimum 30% clay, 0-40% silt and 0-30% sand) in closing breach or channel for double handling in final closing with all leads and lifts including clod breaking , dressing and ramming etc. complete (applicable in case of final closing portion only) as per direction of Engineer in charge.	cum
16-370-10	300m. to 1.00 km.	cum
16-370-20	1.00 km.to 5.00 km. (Extra rate)	cum

ITEM DEFINITION REPORT

ItemCode	Item Description	Unit Meas.
16-380	Earth work by carried (by truck/boat or any other means) earth supplied at contractor's own cost (including royalty) with clayey soil (minimum 30% clay, 0-40% silt and 0-30% sand) for closing breach or channel with all leads and lifts within the channel width including clod breaking, ramming etc. complete beyond 300m from the centre of the channel as per direction of Engineer in charge.	cum
16-380-10	300m to 1.00 km. (Extra rate)	cum
16-380-20	1.00 km.to 5.00 km. (Extra rate)	cum
16-390	Manufacturing, supplying and laying matha (average dia 0.9m) of golpata, straw and clayee soil tied with straw rope and fixing in position with bamboo of 60mm to 80mm dia and 3.0m to 3.7m long at 2.4m (average) apart for construction of closure dam etc. complete including the cost of all materials as per direction of Engineer in charge.	cum
16-400	Manufacturing and supplying packed straw bundles (average dia 0.9m and 1.20m long) tied with straw rope and laying in position for construction of closure dam etc. complete including the cost of all materials as per direction of Engineer in charge.	bundle
16-410	Earth work by carried earth (by truck/boat or any other means) supplied at contractor's own cost (including royalty) in constructing/ resectioning of the embankment/ canal bank/ road etc. compacted to 85%/90% maximum dry density at optimum moisture content with reference to laboratory density test AASHTO modified hammer, with clayey soil (minimum 30% clay, 0-40% silt and 0-30% sand) beyond initial lead of 300m including throwing the spoils to profiles in layer not exceeding 230mm in thickness with clod breaking to maximum size of 100mm, benching the side slopes, removing roots and stumps of trees of girth upto 200mm, stripping/ ploughing the base of embankment and borrow pit area, dug bailing, clearing jungles, bail out of water, rough dressing including 150mm cambering at the centre of crest with all leads and lifts complete (compaction will be done by the contractor with approved equipment including all ancillary charges for compaction and testing) as per direction of Engineer in charge.	cum
16-410-10	300m to 1.00 km.(85% compaction)	cum
16-410-20	1.00 km.to 5.00 km. 85% compaction,(Extra rate).	cum
16-410-30	300m to 1.00 km. 90% compaction;	cum
16-410-40	1.00 km.to 5.00 km. 90% compaction, (Extra rate)	cum

ITEM DEFINITION REPORT

ItemCode	Item Description	Unit Meas.
16-420	Earth work by carried earth (by truck/boat or any other means) supplied at contractor's own cost (including royalty) in constructing cross bundh or ring bundh, with clayey soil (minimum 30% clay, 0-40% silt and 0-30% sand) beyond initial lead of 300m with all leads and lifts, throwing the earth in layer not exceeding 150mm in thickness, including clod breaking, benching the side slopes, rough dressing, clearing the jungles, removing the stumps, dug bailing and 75mm cambering etc. complete as per design specification and direction of Engineer in charge.	cum
16-420-10	300m to 1.00 km.	cum
16-420-20	1.00 km. to 5.00 km. (Extra rate)	cum
16-430	Earth work by carried earth by truck/boat or any other means) supplied at contractor's own cost (including royalty) beyond initial lead of 300m, in resectioning/ repair of old embankment/ road as per design and specification with clayey soil (minimum 30% clay, 0-40% silt and 0-30% sand) including removal of weeds, bush etc. if any, breaking clods, dressing etc. complete with all leads and lifts as per direction of Engineer in charge.	cum
16-430-10	300m to 1.00 km.	cum
16-430-20	1.00 km.to 5.00 km. (Extra rate)	cum
16-440	Earth work by borrowing earth from river bed (all kind of soil but excluding organic material) and carried to site by any means by contractor constructing/re-sectioning of embankment with in initial distance of 1.0 km and with all necessary lift including throwing the earth to profiles in layers not exceeding150 mm in thickness with prior preparation of base of the embankment by stripping/ploughing, dug bailing, cutting trees up to 200 mm girth with uprooting stumps, clearing jungles, bailing out water, breaking clods, benching the side slopes, rough dressing and cambering the crest to a height of 150 mm at the center and compacting to 85%/90% minimum dry density at optimum moisture content with reference to laboratory density test AASHTO modified hammer with suitable equipment dressing etc complete as per design specification and direction of Engineer-in-charge. Location of river bed from where earth will be collected and quality of borrow soil must have prior approval from the Engineer-in-charge. In no circumstances, earth shall be borrowed from agricultural/homestead land. The borrow earth have to be collected from river bed by avoiding any detrimental impact on the river channel.	cum
16-440-10	Borrowed earth from river bed: From 0.00 m to 1.00 km (85% compaction).	cum
16-440-20	Borrowed earth from river bed: Beyond1.00 km to 5.00 km, 85% compaction (extra rate).	cum
16-440-30	Borrowed earth from river bed: From 0.00 m to 1.00 km (90% compaction).	cum
16-440-40	Borrowed earth from river bed: Beyond1.00 km to 5.00 km, 90% compaction (extra rate).	cum

ITEM DEFINITION REPORT

ItemCode	Item Description	Unit Meas.
16-450	Providing clay blanket/clay core by carried earth supplied at contractor's own cost (including royalty) in different thickness over embankment crest and side slopes/embankment core/bed and slope of irrigation canal/crest and side slopes of irrigation canal dykes etc. with selected clay (clay content minimum 80% and silt content maximum 20%) including throwing clay in layers not exceeding 150mm in thickness, clod breaking, benching the side slopes, and compacting to 85% maximum dry density at optimum moisture content with suitable equipment, dressing etc. complete (clay blanket should be extended upto 0.5m below the berm on the outside of embankment/ irrigation canal dyke etc.) as per design, specification and direction of Engineer in charge.	cum
16-450-10	0.00m to 3000m.	cum
16-450-20	Carried by truck/boat or any means: 300m to 1.0km.	cum
16-450-30	Carried by truck/boat or any means:1.0km.to 5.0km.(Extra rate)	cum
16-460	Providing clay cover by carried earth by any means in different thickness over the side slopes or crest of the embankment or clay core in side the embankment with selected soil (clay content minimum 80% and silt content 0-20%) including throwing clay in layers not exceeding 150 mm in thickness, clod breaking, benching the side slopes and compacting to 90% minimum dry density at optimum moisture content with reference to laboratory density test AASHTO modified hammer with suitable equipment dressing etc. complete as per direction of Engineer-in-charge. Composition of specified soil must be confirmed by laboratory test (from a recognized Institute) before use. Compaction of the soil must also be confirmed by test (expenditure for all Test is the responsibility of contractor).	cum
16-460-10	Carried earth by any means: From 0.00 m to 1.00 km.	cum
16-460-20	Carried earth by any means: Beyond 1.00 km to 5.00 km (Extra rate).	cum
16-470	Earth work by manual labour in all kinds of soil for excavation/ re-excavation of pond/ tank and constructing bank as per design and specification, throwing the spoil earth in layers of 150mm including breaking clods, dressing, profiling etc. complete with all leads and lifts as per direction of Engineer in charge.	cum
16-470-10	For ordinary soil.	cum
16-470-20	For slushy or percolating soil.	cum
16-510	Earth filling in foundation trenches, plinth and back filling including consolidation in 150mm layer, watering etc. complete (building only) as per direction of Engineer in charge.	cum
16-520	Supplying and filling sand in foundation of hydraulic structures, buildings and in protective works with selected sand, in 150mm thick layer, including levelling, dressing, ramming, watering etc. complete (compacted to 50% relative density by manual labour using mallet/ vibro compactor) as per direction of Engineer in charge.	cum
16-520-10	sand of FM \geq 1.00	cum

ITEM DEFINITION REPORT

ItemCode	Item Description	Unit Meas.
16-520-20	sand of FM \geq 1.50	cum
16-530	Back filling in hydraulic structures and slope building in protective works including all leads and lifts with selected local soil in layer of 150mm including watering, ramming etc. complete compacted to 20% relative density by compactor or any other suitable method as per direction of Engineer in charge.	cum
16-540	Back filling in hydraulic structures including all leads and lifts in 150mm layer including watering, ramming, compacting to 30% relative density etc. complete by compactor or any other suitable method as per direction of Engineer in charge.	cum
16-540-10	Sand of FM \geq 0.50	cum
16-540-20	Sand of FM \geq 0.80	cum
16-560	Shoring for slope protection of foundation trench, canal, embankment, road, pond etc. as per design slopes, grades including removal of spoils to a safe distance as per direction of Engineer in charge.	sqm
16-560-10	By bamboo post of 6.0m length, 60mm to 80mm dia, 25 cm c/c and 2.0m drive with diagonally woven tarza walling and average 70mm dia half split bamboo batten @ 2.0m c/c fixed with nails.	sqm
16-560-20	By bamboo post of 6.0m length, 60mm to 80mm dia, 20cm c/c, driven 2.0m below ground, with drum sheet walling and average 70mm dia half split bamboo batten @ 2.0m c/c fixed with nails.	sqm
16-560-30	By local hard wood ballah post of 6.0m length, 125mm dia, 1.0m c/c, and 2.0m drive with 6.0m long bamboo of average 75mm dia, @ 1.0m c/c and 2.0m drive with drum sheet walling and average 70mm dia half split bamboo batten @ 2.0m c/c fixed with nails.	sqm
16-600	Earth work by Mechanical Excavator (Long Boom) in all kinds of soil in excavation / re-excavation of channel/canal/khal etc. Including disposal of spoil-soil upto 30m away from the point of excavation with rough dressing and levelling etc. complete as per direction of Engineer-in-Charge.	cum
16-615	Extra Rate for every additional shift of Dredged/Excavated earth or shifting of earth by Mechanical Excavator (Long Boom) of 30m or part thereof beyond the initial shift of 30m upto a maximum of 9 shift for all kind of earthwork shift. (Unit: per shift per cum)	pspc
16-620	Extra Rate for Carriage of Dredged earth/Excavated earth or shifting of earth by dump truck including loading, unloading complete as per direction of Engineer in charge. Extra Rate for Carriage of Dredged earth/Excavated earth by dump truck including loading, unloading complete as per direction of Engineer in charge.	
16-620-10	Carriage by Dump Truck: Up to 1.0 km	cum
16-620-20	Carriage by Dump Truck: Above 1.0 km	cum/km

ITEM DEFINITION REPORT

ItemCode	Item Description	Unit Meas.
16-630	Extra Rate for Carriage of Dredged earth/Excavated earth by cargo/Engine boat or by any other means including loading, unloading complete as per direction of Engineer in charge.	
16-630-10	Carriage by Boat/Cargo: Up to 1.0 km	cum
16-630-20	Carriage by Boat/Cargo: Above 1.0 km	cum/km
16-640	Earth work by Mechanical Excavator (Long Boom) in constructing/resectioning of embankment/canal bank/road etc. with clayey soil (minimum 30% clay, 0-40% silt and 0-30% sand) within the initial lead of 30m, and all lifts including throwing the spoils to profiles in layers not exceeding 150mm in thickness, clod breaking upto a maximum size of 100mm, benching the side slopes, stripping/ploughing the base of embankment and borrow pit area, dug bailing, cutting trees upto 200mm girth, with uprooting stumps, clearing jungles, rough dressing and 150mm cambering at the centre of the crest etc. complete as per specification and direction of Engineer in charge.	cum
16-640-10	Embankment by mechanical excavator, ht: 0 to 4 m	cum
16-640-20	Embankment by mechanical excavator, ht: 4 to 6 m and above	cum
16-650	Earth work by Mechanical Excavator (Long Boon) in constructing/ resectioning of embankment/canal bank/ road etc. compacted to 85%/90% maximum dry density at optimum moisture content, with reference to laboratory density test AAHSTO modified hammer, with clayey soil(minm 30% clay, 0-40% silt, 0-30% sand) within the initial lead of 30m and all lifts including throwing the spoils to profiles in layers not exceeding 230mm in thickness with clod breaking to a maximum size of 100mm, benching the side slopes, removing roots and stumps of trees of girth upto 200mm from the ground, stripping/ploughing the base of embankment and borrow pit area, dug bailing, rough dressing including 150mm cambering at the centre of crest etc. complete, including maintenance of the same for 6 months after completion, (compaction will be done by the contractor with approved equipment, including all ancillary charges for compaction and testing) as per direction of Engineer in charge.	cum
16-650-10	Embankment by Mech. Equipment; ht: 0 to 4m; 85% comp.	cum
16-650-20	Embk. by Mech. Equipment; ht: 4 to 6m & above; 85% comp.	cum
16-650-30	Embk. by Mech. Equipment; ht: 0 to 4m; 90% comp.	cum
16-650-40	Embk. by Mech. Equipment; ht: 4 to 6m & above; 90% comp.	cum

ITEM DEFINITION REPORT

ItemCode	Item Description	Unit Meas.
16-660	Earth work by carried earth (by truck/boat or any other means) supplied at contractor's own cost (including royalty) in constructing/ resectioning of the embankment/ canal bank/ road etc. by Mechanical Excavator (Long Boon) compacted to 85%/90% maximum dry density at optimum moisture content with reference to laboratory density test AASHTO modified hammer, with clayey soil (minimum 30% clay, 0-40% silt and 0-30% sand) beyond initial lead of 300m including throwing the spoils to profiles in layer not exceeding 230mm in thickness with clod breaking to maximum size of 100mm, benching the side slopes, removing roots and stumps of trees of girth upto 200mm, stripping/ ploughing the base of embankment and borrow pit area, dug bailing, clearing jungles, rough dressing including 150mm cambering at the centre of crest with all leads and lifts complete (compaction will be done by the contractor with approved equipment including all ancillary charges for compaction and testing) as per direction of Engineer in charge.	cum
16-660-10	300 m to 1 km and EmbK. ht: 0 to 4 m with 85% Comp.	cum
16-660-20	300 m to 1 km and Embk. ht: 4 to 6 m and above with 85% Comp.	cum
16-660-30	300 m to 1 km and Embk. ht: 0 to 4 m with 90% Comp.	cum
16-660-40	300 m to 1 km and Embk. ht: 4 to 6 m and above with 90% Comp.	cum
16-660-50	1 km to 5 km and Embk. ht: 0 to 4 m with 85% Comp.	cum
16-660-60	1 km to 5 km and Embk. ht: 4 to 6 m and above with 85% Comp.	cum
16-660-70	1 km to 5 km and Embk. ht: 0 to 4 m with 90% Comp.	cum
16-660-80	1 km to 5 km and Embk. ht: 4 to 6 m and above with 90% Comp.	cum

ITEM DEFINITION REPORT

ItemCode	Item Description	Unit Meas.
20 . Brick Work		
20-100	Single brick flat soling including preparation of bed, sand filling (FM \geq 0.50), levelling, dressing and sand blinding in foundation or floor with supply of all materials etc. complete and as per direction of Engineer in charge.	sqm
20-100-10	With 1st class bricks	sqm
20-100-20	With 2nd class bricks.	sqm
20-200	Brick work with 1st. class bricks in cement mortar (sand of FM \geq 1.50) in foundation and plinth, including soaking bricks in clean water for 6 hours, cleaning the bricks, raking out joints, staging, sorting, curing at least for 7 days , including supply of all materials etc. complete and as per direction of Engineer in charge.	cum
20-200-10	proportion: 1:4	cum
20-200-20	proportion: 1:6	cum
20-220	Extra rate for brick work in superstructure in different stories, over the rates of brick work in foundation and plinth:	cum
20-220-10	Ground floor superstructure	cum
20-220-20	1st. floor superstructure	cum
20-220-30	2nd. floor superstructure	cum
20-220-40	3rd. floor and above superstructure	cum
20-230	125 mm thick brick work with 1st. class bricks in cement mortar (sand of FM \geq 1.50) including soaking bricks in clean water for 6 hours, cleaning the bricks, raking out joints, staging, sorting, curing at least for 7 days, including supply of all materials etc. complete (in ground floor) and as per direction of Engineer in charge:	cum.
20-230-10	proportion: 1:3	sqm
20-230-20	proportion: 1:4	sqm
20-240	Extra rate for 125mm thick brick work in superstructure in different stories over the rate of brick work in ground floor.	sqm
20-240-10	First floor superstructure.	sqm
20-240-20	Second floor superstructure.	sqm
20-240-30	Third floor superstructure and above.	sqm

ITEM DEFINITION REPORT

ItemCode	Item Description	Unit Meas.
20-250	Brick work with 10 hole machine made ceramic bricks of approved size having uniform colour, carefully laid in cement mortar 1:4 (sand of FM \geq 1.50) in ground floor superstructure with uniform width and depth of joints true to vertical and horizontal lines, including soaking bricks in clean water for 6 hours, cleaning the bricks, raking out joints, staging, sorting, pointing with cement mortar (1:2), cleaning the surface, including supply of all materials etc. complete and as per direction of Engineer in charge.	cum
20-260	Extra rate for 10 hole machine made ceramic brick work in superstructure of different stories over the rate of brick work in ground floor etc. complete as per direction of Engineer in charge.	cum
20-260-10	First floor Superstructure.	cum
20-260-20	Second floor Superstructure.	cum
20-260-30	Third floor Superstructure.	cum
20-280	75mm thick brick work with 1st. class bricks in all kinds of works in cement mortar 1:3 (sand of FM \geq 1.5) including soaking bricks, raking out joints, staging, sorting, cleaning the surface, curing at least for 14 days including the cost of all materials etc. complete as per direction of Engineer in charge.	sqm
20-290	Providing brick work in facing in superstructure with 200mm x 50mm x 50mm machine made ceramic pressed bricks of approved quality with cement mortar 1:4 (sand of FM \geq 1.50) including soaking bricks in clean water for 6 hours, cleaning the bricks, raking out joints, staging, sorting, high class ruled pointing, cleaning the surface, curing at least for 7 days, including supply of all materials etc. complete for all floors as per direction of Engineer in charge.	sqm
20-300	125 mm thick jally brick work in cement mortar 1:4,(sand of FM \geq 1.50) including soaking bricks in clean water for 6 hours, cleaning the bricks, raking out joints, staging, sorting, cleaning the surface, curing at least for 14 days, including supply of all materials etc. complete for all floors as per direction of Engineer in charge.	sqm

ITEM DEFINITION REPORT

ItemCode	Item Description	Unit Meas.
24 . Plastering Work		
24-100	Minimum 20mm thick sand cement plaster, (sand of FM \geq 1.3) in ground floor, including scaffolding, raking out joints, making sharp edges and corners, cleaning the surface, curing for at least seven days etc. complete including the cost of all materials and as per direction of Engineer in charge.	sqm
24-100-10	proportion 1:4	sqm
24-100-20	proportion 1:6	sqm
24-110	Extra rate for 20mm thick sand cement plaster, in super structure for each floor over ground floor.	sqm
24-110-10	proportion 1:4	sqm
24-110-20	proportion 1:6	sqm
24-130	Minimum 12mm thick sand cement plaster, (sand of FM \geq 1.30) in ground floor, including scaffolding, raking out joints, making sharp edges and corners, cleaning the surface, curing for at least 7 days etc. complete including the cost of all materials and as per direction of Engineer in charge.	sqm
24-130-10	Proportion 1:4.	sqm
24-130-20	Proportion 1:6.	sqm
24-140	Extra rate for 12mm thick sand cement plaster in super structure for each floor over ground floor.	sqm
24-140-10	Proportion 1:4.	sqm
24-140-20	Proportion 1:6.	sqm
24-160	Minimum 6mm thick sand cement plaster (sand of FM \geq 1.30) over concrete faces , in ground floor super structure, including chipping the surfaces, scaffolding, making sharp edges and corners, cleaning the surface, curing for at least 7 days etc. complete including the cost of all materials and as per direction of Engineer in charge.	sqm
24-160-10	Proportion 1:3.	sqm
24-160-20	Proportion 1:4.	sqm
24-170	Extra rate for 6mm thick sand cement plaster in super struture for each floor over ground floor,	sqm
24-170-10	Proportion 1:3.	sqm
24-170-20	Proportion 1:4.	sqm
24-180	Neat cement finishing on plaster surfaces just after initial setting of plaster in all floors including curing at least for seven days with supply of all materials etc complete as per direction of Engineer in charge.	sqm

ITEM DEFINITION REPORT

ItemCode	Item Description	Unit Meas.
24-200	Drip coarse at the edge of sunshade or cornices, with 1:4 sand cement mortar (sand of FM \geq 1.30) including cleaning the surface, curing for at least 7 days, scaffolding etc. complete in all floors with supply of all materials and as per direction of Engineer in charge.	m
24-300	Rule pointing to brick work in sand cement mortar (sand of FM \geq 1.3), including scaffolding, curing, raking out joints, clearing the surfaces etc. complete in all floors, with supply of all materials and as per direction of Engineer in charge.	sqm
24-300-10	proportion 1:2	sqm
24-300-20	proportion 1:3	sqm
24-310	Flush pointing to brick works, in sand cement mortar (sand of FM \geq 1.3), including scaffolding, curing, raking out joints, clearing the surface etc. complete in all floors including the cost of all materials and as per direction of Engineer in charge.	sqm
24-310-10	proportion 1:2	sqm
24-310-20	proportion 1:3	sqm

ITEM DEFINITION REPORT

ItemCode	Item Description	Unit Meas.
26 . Admixture		
26-100	Water Reducer & Plasticizer for Pilling : Supplying and applying specified type of chemical such as Con-Lub or equivalent, confirming the current chemical specification requirements like physical properties, uniformity & equivalence in composition etc. for the treatment of Water Reducing, strength gaining, better workability, anti-corrosive, no segregation, perfect compaction etc. Prepare concrete screening using 300 ml - 750 ml Con-Lub with 50kg cement. Initially 300 ml - 750 ml Con-Lub for 1 bag cement is to be mixed with required amount of water which will be used in preparation of concrete or doges mentioned in the manufacturer's brochures and strictly following the recommendation and instruction, providing safety provision in all respect etc. All complete as per direction of the E-I-C.	Ltr
26-150	Water Reducer & Plasticizer for Superstructure, Block & other Concretes: Supplying and applying specified type of chemical such as Con-Lub or equivalent, confirming the current chemical specification requirements like physical properties, uniformity & equivalence in composition etc. for the treatment of Water Reducing, strength gaining, better workability, anti-corrosive, no segregation, perfect compaction etc. Prepare concrete screening using 250 ml - 700 ml Con-Lub with 50kg cement. Initially 250 ml - 700 ml Con-Lub for 1 bag cement is to be mixed with required amount of water which will be used in preparation of concrete or doges mentioned in the manufacturer's brochures and strictly following the recommendation and instruction, providing safety provision in all respect etc. All complete as per direction of the E-I-C.	Ltr
26-200	Chemical for Water Proofing Basement Floor, Ground Floor, Retaining walls, Water Reservoirs, Water Tank, ETP, WETP or Drain Concreting etc: Supplying and applying specified type of chemical such as Foam-Lub or equivalent, confirming the current chemical specification requirements like physical properties, uniformity & equivalence in composition etc. for the treatment of Water & Damp Proofing, vibration tolerance, better compatibility,void & porosity reducing, Reduce permeability of concrete, shrinkage factor controlling of heat of hydration etc. Prepare Concrete screening using 500 ml Foam-Lub with 50kg of cement. Initially 500 ml Foam-Lub for 1 bag cement is to be mixed with required amount of water which will be used in preparation of concrete or doges mentioned in the manufacturer's brochures and strictly following the recommendation and instruction, providing safety provision in all respect etc. All complete as per direction of the E-I-C.	Ltr

ITEM DEFINITION REPORT

ItemCode	Item Description	Unit Meas.
26-250	<p>Chemical for Anti Salinity & Damp Proofing Plaster Work (Inside & outside Wall) : Supplying and applying specified type of chemicals such as Desalt-S01 and Foam-Lub or equivalent, confirming the current chemical specification requirements like physical properties, uniformity & equivalence in composition etc. for the treatment of Anti-salinity, Damp proofing, Partial auto Curing, Reduce hair Cracks etc. at inside and outside brick walls. Prepare a mixture with the proportion of 1 liter Desalt-S01, 10 liter Water and 25ml or 1 div Catalyst. Cleaning the surface properly and apply one coat of Desalt-S01 mixture with a jute brush or spray over the exposed brick surface (before plaster). Use the mixture within 2 hours of preparation. After that, prepare sand-cement mortar for plastering work using admixture as Foam-lub 250 ml with 50kg cement. Initially 250 ml Foam-lub for 1bag cement is to be mixed with required amount of water which will be used in preparation of sand cement mortar or doges mentioned in the manufacturer’s brochures and strictly following the recommendation and instruction, providing safety provision in all respect etc. all complete as per direction of the E-I-C. (Excluding cost of Plastering Work).</p>	Sqm
26-300	<p>Chemical for Anti Salinity, Damp & Water-Proofing Liquid Felt treatment: Supplying and applying specified type of chemicals such as Desalt-S01, Hydroseal Ef-32, Foam-Lub and associates materials (Coal-Tar, Kerosin) or equivalent, confirming the current chemical specification requirements like physical properties, uniformity & equivalence in composition etc. for the treatment of Damp & water Proofing liquid Felt membrane at Basement floor, Roof gardening etc . To Prepare a mixture in proportion of 1 liter of Desalt-S01, 10 liters of water and 25 ml of Catalyst. Apply 1 Coat of the mixture within 2 hours of Preparation with a Jute Brush. Then Prepare a mixture of 4 liters of Hydro seal Ef-32, 4 liters of water, 100 ml of T-Catalyst and 50 ml of R-Catalyst in a Bucket. In another Bucket Prepare a mixture of 4 liters of Coal-tar and 1 liter of Kerosin, Mix the elements of the Buckets together properly. Apply 3 Coats of prepared mixture with Jute Brush on the floor surface at an interval of 12 hours; water will be reduced by 2 liters in the 2nd Coat and without water in the 3rd Coat. After applying 3rd coat, spread cement on it and make 3” CC casting. To prepare a mixture of Concrete in proportion of 250 ml Foam-Lub with 50 Kg of Cement. Initially 250 ml Foam-Lub for 1 bag cement is to be mixed with required amount of water which will be used in preparation of concrete or doges mentioned in the manufacturer's brochures and strictly following the recommendation and instruction, providing safety provision in all respect etc. All complete as per direction of the E-I-C.</p>	sqm

ITEM DEFINITION REPORT

ItemCode	Item Description	Unit Meas.
26-350	<p>Chemical for Heat Reducing & Water-Proofing treatment for Patent stone Concrete: Supplying and applying specified type of chemical such as Foam-Lub (Meta) or equivalent, confirming the current chemical specification requirements like physical properties, uniformity & equivalence in composition etc. for the treatment of Heat insulating & Water proofing Patent stone Concrete. At first, Chipping and clean the surface of base concrete properly. Then Prepare a mixture of Curdy- Dense Foam-Lub (Meta) Cement grout in proportion of 2 liters of Foam-Lub (Meta), 40 liters of Water and 1 bag or 50 Kgs of cement. Apply prepared Cement Grout with a broom on Roof surface properly. After applying Cement Grout, make average 3” patent stone casting. To prepare a mixture of Concrete Screeding in proportion of 500 ml Foam-Lub (Meta) with 50 Kg of Cement. Initially 500 ml of Foam-Lub (Meta) is to be mixed with required amount of water which will be used in preparation of concrete that needs 50 Kgs or 1 bag of Cement and Wire Mesh (22 Gage) or Expanding Metal Net (1" to 1.5"gap) have to use in middle position of the patent stone. Curing properly and Use the mixture within 1 hour of preparation or doges mentioned in the manufacturer's brochures and strictly following the recommendation and instruction, providing safety provision in all respect etc. All complete as per direction of the E-I-C. (Excluding cost of concrete Screeding, 1:1.5:3)</p>	sqm
26-400	<p>Chemical for Heat Reducing & Water-Proofing Roof Slab treatment : Supplying and applying specified type of chemical such as Foam-Lub (Meta) or equivalent, confirming the current chemical specification requirements like physical properties, uniformity & equivalence in composition etc. for the treatment of Heat insulating & Water proofing Roof Slab. Prepare Concrete screening using 500 ml Foam-Lub (Meta) with 50 Kg of Cement. Initially 500 ml of Foam-Lub (Meta) is to be mixed with required amount of water which will be used in preparation of concrete that needs 50 Kgs or 1 bag of Cement or doges mentioned in the manufacturer's brochures and strictly following the recommendation and instruction, providing safety provision in all respect etc. All complete as per direction of the E-I-C.</p>	Ltr

ITEM DEFINITION REPORT

ItemCode	Item Description	Unit Meas.
26-450	<p>Chemical for fair face Treatment on sand, stones, ceramics & ordinary brick works: Supplying and applying specified type of chemicals such as Desalt-S01 and Hydro-Seal, Ef-34 or equivalent, confirming the current chemical specification requirements like physical properties, uniformity & equivalence in composition etc. for Machine Made/Ceramic brick face treatment on claded or normal exposed fair face brick and sand stone to prevent salinity, water absorption and growth of algae. To Prepare a mixture in proportion of 1 liter of Desalt- S01, 10 liter of Water and 25ml or 1 point/mark of Catalyst. Apply one coat of mixture with a jute brush or spray. Use the mixture within 2 hours of preparation. After 12 hours of application, clean the surface with water using soft brush. Wait 4 days minimum for drying the surface. On dried up surface, apply one coat of Hydro-Seal, Ef-34 mixture prepared in proportion of 1 litre of Hydro-Seal Ef-34, 6 litre of water and 25 ml or 1 point/mark of T. catalyst using jute brush. After one day apply second coat of Hydro-Seal,Ef-34 mixture prepared in proportion of 1 liter of hydro-Seal, Ef-34, 5 liter of water & 25 ml or 1 point/mark of T. catalyst on the same dried surface. Again after one day of the applying 2 nd coat, apply third coat of hydro-Seal,Ef-34 mixture prepared in same proportion of second coat on the same dried surface or doges mentioned in the manufacturer's brochures and strictly following the recommendation and instruction, providing safety provision in all respect etc. All complete as per direction of the E-I-C.</p>	Sqm
26-500	<p>Chemical for Anti-termite treatment : Supplying and applying specified type of chemical such as Pestearthly of Baral Chemicals or equivalent best quality, confirming the current chemical specification requirements like physical properties, uniformity & equivalence in composition etc. for the treatment of Anti-termite inside (Floor) of building & outside (Barrier) of building :</p> <p>a. Inside (Floor) of building : At first fill the floor with sand and soil. Then spread Pestearthly equally on the surface of the floor. 1 kg Pestearthly spread 300 sft of coverage area.</p> <p>b. Outside (Barrier) of building : Dig the canal in the soil outside and attached to the external wall and make a surrounding canal of 600 mm wide and 600 mm deep. Spread Pestaerthy equally on the bottom layer of the canal. Fill up half of the canal with soil or sand. Then spread Pestearthly as 2nd layer the half-filled canal by the same way.After that fill up the 3/4 of the canal with soil or sand and spread Pestearthly as 3rd or final layer on the surface and fill the rest part of the canal with sand,soil,cement concrete etc. Pestearthly 1 kg spread surrounding canal of 3 layers by 12.20 meter or doges mentioned in the manufacturer's brochures and strictly following the recommendation and instruction, providing safety provision in all respect etc. All complete as per direction of the E-I-C.</p>	Kg

ITEM DEFINITION REPORT

ItemCode	Item Description	Unit Meas.
26-550	Chemical for Anti-termite treatment in affected building Wall & Wood Furnitures : Supplying and applying specified type of chemicals such as Pestonol or equivalent, confirming the current chemical specification requirements like physical properties, uniformity & equivalence in composition etc. for the treatment of Anti -termite. To Prepare a mixture in proportion of 1 liter of Pestonol and 20 liter of Water. Then Apply prepared mixture on the surface of the affected building wall & furniture with a spray machine or inject the affected area. Use the mixture within 2 hours of preparation or doges mentioned in the manufacturer's brochures and strictly following the recommendation and instruction, providing safety provision in all respect etc. All complete as per direction of the E-I-C.	Ltr
26-600	Chemical for Salinity Protective & Sulphate Resistance: Supplying and applying specified type of chemical such as Con Lub-S or equivalent, confirming the current chemical specification requirements like physical properties, uniformity & equivalence in composition etc. for the treatment of Salinity Protective, Sulphate Resistance & Anti-corrosive of Concrete. Prepare concrete screening using 400 ml - 700 ml Con Lub-S with 50kg cement. Initially 400 ml - 700 ml Con Lub-S for 1 bag cement is to be mixed with required amount of water which will be used in preparation of concrete or doges mentioned in the manufacturer's brochures and strictly following the recommendation and instruction, providing safety provision in all respect etc. All complete as per direction of the E-I-C.	Ltr
26-650	Chemical for Anti-Salinity & Damp Proofing Repairing Work of old Building: Supplying and applying specified type of chemicals such as Desalt-S01 and Foam-Lub or equivalent, confirming the current chemical specification requirements like physical properties, uniformity & equivalence in composition etc. for the treatment of Anti-salinity & damp proofing Repairing work. First of all, Remove existing plaster and pointing on the damped wall/surface concern and clean the surface properly with broom, do not use water. Then Prepare a mixture in proportion of 1 liter of Desalt-S01, 10 liter water and 25 ml or 1 div catalyst. Apply one coat of the mixture within 2 hours of preparation on exposed concrete surface/brick walls with a jute brush. Prepare a mixture of Curdy-Dense Foam-Lub Cement Grout in proportion of 2 liters Foam-Lub, 35 liters of water and 50 kgs cement. Apply 3 coats of prepared Cement Grout with a jute brush on the brick walls/concrete surfaces at an interval of 6 hours. Sand-Cement plaster work will be started after application of 3rd coat of curdy-dense Foam-Lub cement grout. After that, Prepare sand-cement mortar for plastering work using admixture as Foam-Lub 500 ml with 50 kg cement. Initially 500 ml Foam-Lub for 1 bag cement is to be mixed with required amount of water which will be used in preparation of sand cement mortar or doges mentioned in the manufacturer's brochures and strictly following the recommendation and instruction, providing safety provision in all respect etc. All complete as per direction of the E-I-C. (Excluding cost of Plastering Work)	Sqm

ITEM DEFINITION REPORT

ItemCode	Item Description	Unit Meas.
28 . Concrete Construction		
28-100	Cement concrete work in leanest mix. 1:4:8, with sand of FM \geq 1.5, in foundation or floor, including breaking, screening, grading and washing aggregates with clear water, mixing, laying in position, consolidation to levels, curing, including supply of all materials, excluding the cost of formworks etc. complete as per direction of Engineer in charge.	cum
28-100-10	With 25mm down graded picked jhama or 1st. class brick chips.	cum
28-100-20	With 25mm down graded stone chips.	cum
28-100-30	With 25mm down graded stone shingles.	cum
28-100-40	With 40mm down graded picked jhama or 1st. class brick chips.	cum
28-100-50	With 40mm down graded stone chips.	cum
28-100-60	With 40mm down graded stone shingles.	cum
28-120	Cement concrete work in leanest mix. 1:3:6 with sand of FM \geq 1.5, in foundation or floor including breaking, screening, grading and washing aggregates with clear water, mixing, laying in position, consolidation to levels, curing, including supply of all materials, excluding the cost of formworks etc. complete as per direction of Engineer in charge.	cum
28-120-10	With 25mm down graded picked jhama or 1st. class brick chips.	cum
28-120-20	With 25mm down graded stone chips.	cum
28-120-30	With 25mm down graded stone shingles.	cum
28-120-40	With 40mm down graded picked jhama or 1st. class brick chips.	cum
28-120-50	With 40mm down graded stone chips.	cum
28-120-60	With 40mm down graded stone shingles.	cum
28-130	Reinforced Cement Concrete Works in leanest mix. 1:2:4 with 25mm down graded coarse aggregates and sand of FM $>$ 1.5, to attain a minimum 28 days cylinder strength of 16.0 N/mm ² , including breaking, screening, grading, washing aggregates with clear water, mixing, laying in forms, consolidation to levels, curing, including supply of all materials, excluding the cost of M.S. work for reinforcements and formworks etc. complete and as per direction of Engineer in charge.	cum
28-130-10	With picked jhama or 1st class brick chips.	cum
28-130-20	With stone chips.	cum
28-130-30	With stone shingles.	cum

ITEM DEFINITION REPORT

ItemCode	Item Description	Unit Meas.
28-140	Reinforced Cement Concrete Work in leanest mix. 1:2:4, with 20mm down graded coarse aggregates and sand of FM>1.8 to FM<=2.5, to attain a minimum 28 days cylinder strength of 18.0 N/mm ² , including breaking, screening, grading, washing aggregates with clear water, mixing, laying in forms, consolidation to levels, curing, including supply of all materials, excluding the cost of M.S. work for reinforcement and formworks etc. complete as per direction of Engineer in charge.	cum
28-140-10	With picked jhama or 1st class brick chips.	cum
28-140-20	With stone chips.	cum
28-140-30	With stone shingles.	cum
28-140-40	With local hard rock chips.....	cum
28-150	Reinforced cement concrete work in leanest mix. 1:2:4 with 25mm down graded coarse aggregates and sand of FM>1.8 to FM<=2.5, to attain a minimum 28 day cylinder strength of 18.0 N/mm ² , including breaking, screening, grading and washing aggregates with clear water, mixing, laying in forms, consolidation to levels, curing, including supply of all materials, excluding cost of M.S. work for reinforcements and formworks etc. complete and as per direction of Engineer in charge.	cum
28-150-10	With picked jhama or 1st.class brick chips.	cum
28-150-20	With stone chips.	cum
28-150-30	With stone shingles.	cum
28-170	Reinforced cement concrete work in leanest mix. 1:2:4 with 40mm down graded coarse aggregates and sand of FM>1.8 to FM<=2.5, to attain a minimum 28 day cylinder strength of 18.0 N/mm ² , including breaking, screening, grading and washing aggregates with clear water, mixing, laying in forms, consolidation to levels, curing, including supply of all materials, excluding cost of M.S. work for reinforcements and formworks etc. complete and as per direction of Engineer in charge.	cum
28-170-10	With picked jhama or 1st class brick chips.	cum
28-170-20	With stone chips.	cum
28-170-30	With stone shingles.	cum
28-180	Reinforced cement concrete in leanest mix. 1:2:3.5, with 25mm down graded coarse aggregates and sand of FM>1.8 to FM<=2.5, to attain a minimum 28 day cylinder strength of 20.0 N/mm ² , including breaking, screening, grading, washing aggregates with clear water, mixing, laying in forms, consolidation to levels, curing, including supply of all materials, excluding cost of M.S. work for reinforcements and formworks etc. complete and as per direction of Engineer in charge.	cum
28-180-10	With picked jhama or 1st.class brick chips.	cum

ITEM DEFINITION REPORT

ItemCode	Item Description	Unit Meas.
28-180-20	With stone chips.	cum
28-180-30	With stone shingles.	cum
28-200	Reinforced cement concrete work in leanest mix. 1:1.5:3, with 20mm down graded coarse aggregates and sand of FM>2.0 to FM<=2.5, to attain a minimum 28 day cylinder strength of 22.0 N/mm ² , including breaking, screening, grading, washing aggregates with clean water, mixing, laying in forms, consolidation to levels, curing, including supply of all materials, excluding cost of M.S. work for reinforcements and formworks etc. complete and as per direction of Engineer in charge.	cum
28-200-10	with stone chips	cum
28-200-20	with stone shingles.	cum
28-200-30	With local hard rock chips.....	cum
28-220	Reinforced Cement Concrete work in leanest mix. 1:1.5:3, with 25mm down graded coarse aggregates and sand of FM>2.0 to FM<=2.5, to attain a minimum 28 day cylinder strength of 22.0 N/mm ² , including breaking, screening, grading and washing aggregates with clear water, mixing, laying in forms, consolidation to levels, curing, including supply of all materials, excluding cost of M.S. work for reinforcements and formworks etc. complete and as per direction of Enginner in charge.	cum
28-220-10	with stone chips.	cum
28-220-20	with stone shingles.	cum
28-230	Reinforced Cement Concrete work in leanest mix. 1:1.5:3, with 20mm down graded coarse aggregates and sand of FM>=2.5, to attain a minimum 28 day cylinder strength of 25.0 N/mm ² , including breaking, screening, grading and washing aggregates with clear water, mixing, laying in forms, consolidation to levels, curing, including supply of all materials, excluding cost of M.S. work for reinforcements and formworks etc. complete and as per direction of Enginner in charge.	cum
28-230-10	with stone chips.	cum

ITEM DEFINITION REPORT

ItemCode	Item Description	Unit Meas.
28-240	Pre-stressed cement concrete work in bridge girders and end blocks in leanest mix 1:1.5:3 including necessary admixture with 20mm down well graded crushed stone chips, sand of FM =>2.8 and cement to attain a minimum 28 day cylinder strength of 35 N/mm ² including screening, mixing, laying in forms, consolidation to levels, centering, shuttering with 14 BWG M.S. sheet fitted and fixed with 40mmx40mmx6mm m.s.angle frame and 25mmx6mm F.I.bar stiffener including all necessary ties, battens, struts, nuts and bolts etc. complete, scaffolding, staging with 125mm dia bullah props etc. complete but excluding the cost of M.S.reinforcement and its fabrication in PC girder including supplying anchorage with J-hooks, core helic, steel strips, required numbers of 12/7 mm HT wire and its fabrication in conformity with ASTM 421-80 standard with minimum ultimate strength of 1550 N/mm ² , stressing, making, fitting of sheath including cost and arrangement of post tensioning, casting, launching, shifting, staging arrangement and placing in position, grouting the holes with cement mortar (18 litre water, 50 Kg cement and 1 Kg of grout additive) including the cost of all materials etc. complete as per design, drawing and direction of Engineer in charge.	cum
28-240-10	upto 20.0 m span.	cum
28-240-20	upto 30.0 m span.	cum
28-260	Cement Concrete Wearing Course in leanest mix. (1:1.5:3) with cement, sand of FM>=2.0 to FM<=2.5 and Pea Gravels including screening, washing gravels, mixing, laying, consolidation to levels, finishing, curing including supply of all materials etc. complete as per direction of Engineer in charge.	cum

ITEM DEFINITION REPORT

ItemCode	Item Description	Unit Meas.
36 . Form Work		
36-100	Form work for centering and water tight shuttering as per drawing with minimum 25mm thick wooden plank and batten (minimum size 75mmx50mm), struts and props including covering the surface with 28 BWG plain GI sheet, fitting, fixing by nails, tie rods and nuts & bolts to desired level and shape and removing the forms etc. after specified period including the cost of all materials as per direction of Engineer in charge.	sqm
36-100-10	Vertical and inclined walls, columns, piers with 60-80mm dia barrack bamboo props.	sqm
36-100-20	Deck slab, operating deck slab, top slab of barrel upto 3.5m of height with 60-80mm dia barrack bamboo props.	sqm
36-100-30	Deck slab, operating deck slab, top slab of barrel above 3.5m upto 6.5m height with ≥ 125 mm dia local hard wood bullah props.	sqm
36-100-40	Beams and girders (web portion), in deck/ operation deck (upto 3.5m height) with 60-80mm dia barrack bamboo props.	sqm
36-100-50	Beams and girders (web portion), in deck/operation deck (above 3.5m upto 6.5m height) with ≥ 125 mm dia local hard wood bullah props.	sqm
36-100-60	Footing, footing beams, girder beams, foundation slab with 60-80mm dia barrack bamboo props.	sqm
36-100-70	Sides of roof/floor slab.	sqm
36-140	Form work for centering and water tight shuttering as per drawing with minimum 30mm thick wooden plank with batten (minimum size 75mmx50mm), struts, and ≥ 125 mm dia local bullah props including covering the surface with 28 BWG plain GI sheet, fitting, fixing by nails, tie rods and nuts & bolts to desired level and shape and removing the forms etc. after specified period including the cost of all materials etc. complete as per direction of Engineer in charge.	sqm
36-140-10	Deck slab, operating deck slab, top slab of barrel above 6.5m height.	sqm
36-140-20	Beams, girders (web portion), above 6.5m height.	sqm
36-150	Formwork for centering and water tight shuttering as per drawing with 14 BWG M.S. sheet, fitted and fixed with 40mmx40mmx6mm M.S. angle frame and 25mmx6mm F.I. bar stiffener, with necessary fabrication, welding, making the forms including fitting, fixing of steel forms with necessary ties, battens, struts, nuts & bolts, props etc. as per desired shape and size including levelling and removing the forms after specified period including the cost of all materials as per direction of Engineer in charge.	sqm
36-150-10	Vertical and inclined walls, columns, piers with 60-80mm dia barrack bamboo props.	sqm
36-150-20	Deck slab, operating deck slab, top slab of barrel upto 3.5m height with 60-80mm dia barrack bamboo props.	sqm

ITEM DEFINITION REPORT

ItemCode	Item Description	Unit Meas.
36-150-30	Deck slab, operating deck slab, top slab of barrel above 3.5m upto 6.5m height with 50mm dia GI pipe props.	sqm
36-150-40	Beams and girders (web portion) in deck/operating deck upto 3.5m height with 60-80mm dia barrack bamboo props.	sqm
36-150-50	Beams and girders (web portion) in deck/operating deck above 3.5m upto 6.5m height with 50mm dia GI pipe props.	sqm
36-150-60	Footing, footing beams, grade beams, foundation slab with 60-80mm dia barrack bamboo props.	sqm
36-170	Formwork for centering and water tight shuttering as per drawing with 14 BWG MS sheet fitted and fixed with 40mmx40mmx6mm MS angle frame and 25mmx6mm FI bar stiffener with necessary fabrication, welding and making the frames including fitting, fixing the steel form with necessary ties, battens, struts, nuts & bolts, props etc. as per desired shape and size including levelling and removing the forms after specified period including the cost of all materials etc. complete as per direction of Engineer in charge.	sqm
36-170-10	Deck slab, operating deck slab, top slab of barrel, above 6.5m height with >=125mm dia local hard wood bullah props.	sqm
36-170-20	Beams, girders (web portion) above 6.5m height with >=125mm dia local hard wood bullah props.	sqm
36-300	Form work for centering and water tight shuttering as per drawing with wooden planks of different thickness including supply of polythene sheet (1 kg covering 6.5 sqm) for making shuttering leakproof for all sorts of R.C.C. works in building construction including fitting, fixing by nails, tie rods, nuts and bolts to desired shape and size including levelling and removing the forms etc. after specified period including the cost of all materials as per direction of Engineer in charge.	sqm
36-300-10	Individual and continuous footing of column, raft etc. with 25mm thick wooden planks.	sqm
36-300-20	Foundation beam with 25mm thick wooden planks.	sqm
36-300-30	Padestal, column capital etc. with 40mm thick wooden planks.	sqm
36-300-40	Tie beam, lintel etc. with 40mm thick wooden planks with 51-60mm dia barrack bamboo props.	sqm
36-300-50	Tee beam, ractangular beam etc. (web portion) with 40mm thick wooden planks and >=125mm dia local hard wood bullah props.	sqm
36-300-60	Sunshade, dropwall, cornice, railing etc. with 25mm thick wooden planks with 51-60mm dia barrack bamboo props.	sqm

ITEM DEFINITION REPORT

ItemCode	Item Description	Unit Meas.
36-300-70	Staircase slab, steps etc. with 40mm thick wooden planks with 51-60mm dia barrack bamboo props.	sqm
36-300-80	Floor/roof slab with 25mm thick wooden planks with 60-80mm dia barrack bamboo props.	sqm
36-320	Form work for centering and water tight shuttering as per drawing with minimum 25mm thick wooden plank and batten (75mmx50mm), struts, 60-80mm average dia bamboo props etc. and covering the surface with 28 BWG plain G.I. sheet for RCC works including fitting, fixing by nails, tie rods, nuts & bolts, levelling the top surface and removing the formworks etc. complete, after specified period including the cost of all materials (roof/floor slab only) as per direction of Engineer in charge.	sqm
36-330	Form work for centering and water tight shuttering as per drawing with 28 BWG plain GI sheet cover over minimum 25mm thick wooden plank with batten (75mmx50mm), struts, 60-80mm dia bamboo props etc. as required in stair case, arch or other similar ornamental works including fitting, fixing by nails, tie rods, nuts & bolts to desired shape and size including levelling and removing the formworks etc. after specified period including the cost of all materials as per direction of Engineer in charge.	sqm
36-350	Form work for centering and water tight shuttering as per drawing with 40mm thick wooden plank with batten (minimum size 75mmx50mm), struts, 60-80mm dia bamboo props etc. covering the surface with 28 BWG plain GI sheet as required in columns, lift walls, walls etc. including fitting, fixing by nails, tie rods, nuts & bolts to desired shape including levelling and removing the formworks etc. after specified period including the cost of all materials as per direction of Engineer in charge.	sqm
36-370	Formwork as per drawing in expansion, contraction and construction joints with minimum 25mm thick wooden plank with necessary adjustments for accomodating reinforcing/ dowel bars, water stops etc. including necessary ties, battens, struts, props etc. covering the surface with 28 BWG plain GI sheet as required for RCC works and removing the formworks after specified period etc. complete including the cost of all materials as per direction of Engineer in charge.	sqm

ITEM DEFINITION REPORT

ItemCode	Item Description	Unit Meas.
40 . Protective Work		
40-100	Manufacturing and supplying sand-cement block with cement and sand (FM \geq 1.5), in 1:8 proportion, to attain a minimum 28 day strength of 1.8 N/mm ² , including screening and washing sand, mixing, laying in forms, compacting, curing for at least 14 days including preparation of platform, shuttering etc. complete including supply of all materials and stacking in measurable stacks (steel shutter to be used) as per direction of Engineer in charge.	each
40-100-10	block size 40cmx40cmx30cm.	each
40-100-20	block size 30cmx30cmx30cm.	each
40-100-30	block size 30cmx30cmx20cm.	each
40-100-40	block size 25cmx25cmx25cm	each
40-100-50	block size 20cmx20cmx20cm	each
40-110	Manufacturing and supplying sand-cement block with cement and sand (FM \geq 1.5), in 1:6 proportion, to attain a 28 day minimum strength of 2.5 N/mm ² , including screening and washing sand, mixing, laying in forms, compacting, curing for at least 14 days including preparation of platform, shuttering etc. complete including supply of all materials and stacking in measurable stacks (steel shutter to be used) as per direction of Engineer in charge.	each
40-110-10	block size 40cmx40cmx30cm.	each
40-110-20	block size 30cmx30cmx30cm.	each
40-110-30	block size 30cmx30cmx20cm.	each
40-110-40	block size 25cmx25cmx25cm	each
40-110-50	block size 20cmx20cmx20cm	each
40-120	Labour charge for protective work in laying sand cement blocks of different sizes including preparation of base, ramming of base etc. complete as per direction of the Engineer in charge:	cum
40-120-10	Within 200m.	cum
40-120-20	Beyond 200m.	cum
40-130	Labour charge for salvaging and removing of hard stone boulders or steel slag or brick bats etc. from the slopes and berm of the embankment, stacking the same in a measurable stacks within all leads and lifts as per direction of Engineer in charge.	cum

ITEM DEFINITION REPORT

ItemCode	Item Description	Unit Meas.
40-140	Manufacturing and supplying C.C. blocks in leanest mix. 1:3:6, with cement, sand (FM \geq 1.5) and Stone Chips (40mm down graded), to attain a minimum 28 days cylinder strength of 9.0 N/mm ² including grading, washing stone chips, mixing, laying in forms, consolidation, curing for at least 21 days, including preparation of platform, shuttering and stacking in measurable stacks etc complete including supply of all materials (steel shutter to be used) as per direction of Engineer in charge.	each
40-140-04	Block Size: 60cmx60cmx40cm.	each
40-140-05	Block Size: 50cmx50cmx30cm.	each
40-140-06	Block Size: 40cmx40cmx30cm.	each
40-140-10	Block Size: 60cmx60cmx60cm.	each
40-140-15	Block Size: 50cmx50cmx50cm.	each
40-140-20	Block Size: 50cmx50cmx40cm.	each
40-140-25	Block Size: 45cmx45cmx45cm.	each
40-140-30	Block Size: 45cmx45cmx30cm.	each
40-140-35	Block Size: 40cmx40cmx40cm.	each
40-140-40	Block Size: 40cmx40cmx20cm.	each
40-140-45	Block Size: 35cmx35cmx35cm.	each
40-140-50	Block Size: 30cmx30cmx30cm.	each
40-140-55	Block Size: 30cmx30cmx15cm.	each
40-140-60	Block Size: 25cmx25cmx25cm.	each
40-140-65	Block Size: 20cmx20cmx20cm.	each
40-140-70	Block Size: 45cmx45cmx20cm.	each
40-140-75	Block Size: 40cmx40cmx15cm.	each
40-140-80	Block Size: 50cmx50cmx60cm.	each
40-140-85	Block Size: 50cmx50cmx25cm.	each
40-140-90	Block Size: 50cmx50cmx20m.	each
40-140-95	Block Size: 40cmx40cmx15cm.	each

ITEM DEFINITION REPORT

ItemCode	Item Description	Unit Meas.
40-190	Manufacturing and supplying C.C. blocks in leanest mix. 1:3:6, with cement, sand (FM \geq 1.5) and shingles (40mm down graded), to attain a minimum 28 days cylinder strength of 9.0 N/mm ² including grading, washing shingles, mixing, laying in forms, consolidation, curing for at least 21 days, including preparation of platform, shuttering and stacking in measurable stacks etc complete including supply of all materials (steel shutter to be used) as per direction of Engineer in charge.	each
40-190-04	Block Size: 60cmx60cmx40cm	each
40-190-05	Block Size: 50cmx50cmx30cm	each
40-190-06	Block Size: 40cmx40cmx30cm	each
40-190-10	Block Size: 60cmx60cmx60cm	each
40-190-15	Block Size: 50cmx50cmx50cm	each
40-190-20	Block Size: 50cmx50cmx40cm	each
40-190-25	Block Size: 45cmx45cmx45cm	each
40-190-30	Block Size: 45cmx45cmx30cm	each
40-190-35	Block Size: 40cmx40cmx40cm	each
40-190-40	Block Size: 40cmx40cmx20cm	each
40-190-45	Block Size: 35cmx35cmx35cm	each
40-190-50	Block Size: 30cmx30cmx30cm	each
40-190-55	Block Size: 30cmx30cmx15cm	each
40-190-60	Block Size: 25cmx25cmx25cm	each
40-190-65	Block Size: 20cmx20cmx20cm	each
40-190-70	Block Size: 45cmx45cmx20cm	each
40-190-75	Block Size: 40cmx40cmx15cm	each
40-190-80	Block Size: 50cmx50cmx60cm	each
40-190-85	Block Size: 50cmx50cmx25cm	each
40-190-90	Block Size: 50cmx50cmx20m	each
40-190-95	Block Size: 40cmx40cmx15cm	each

ITEM DEFINITION REPORT

ItemCode	Item Description	Unit Meas.
40-200	Manufacturing and supplying C.C. blocks in leanest mix. 1:3:5.5 with cement, sand (FM \geq 1.5) and Stone Chips (40mm down graded) to attain a 28 days cylinder strength of 10.5 N/mm ² including grading, washing stone chips, mixing, laying in forms, consolidation, curing for at least 21 days, including preparation of platform, shuttering and stacking in measurable stacks etc. complete including supply of all materials (steel shutter to be used) as per direction of Engineer in charge.	each
40-200-04	Block Size: 60cmx60cmx40cm	each
40-200-05	Block Size: 50cmx50cmx30cm	each
40-200-06	Block Size: 40cmx40cmx30cm	each
40-200-10	Block Size: 60cmx60cmx60cm	each
40-200-15	Block Size: 50cmx50cmx50cm	each
40-200-20	Block Size: 50cmx50cmx40cm	each
40-200-25	Block Size: 45cmx45cmx45cm	each
40-200-30	Block Size: 45cmx45cmx30cm	each
40-200-35	Block Size: 40cmx40cmx40cm	each
40-200-40	Block Size: 40cmx40cmx20cm	each
40-200-45	Block Size: 35cmx35cmx35cm	each
40-200-50	Block Size: 30cmx30cmx30cm	each
40-200-55	Block Size: 30cmx30cmx15cm	each
40-200-60	Block Size: 25cmx25cmx25cm	each
40-200-65	Block Size: 20cmx20cmx20cm	each
40-200-70	Block Size: 45cmx45cmx20cm	each
40-200-75	Block Size: 40cmx40cmx15cm	each
40-200-80	Block Size: 50cmx50cmx60cm	each
40-200-85	Block Size: 50cmx50cmx25cm	each
40-200-90	Block Size: 50cmx50cmx20cm	each
40-200-95	Block Size: 40cmx40cmx15cm	each

ITEM DEFINITION REPORT

ItemCode	Item Description	Unit Meas.
40-210	Manufacturing and supplying C.C. blocks in leanest mix. 1:3:5.5 with cement, sand (FM \geq 1.5) and shingles (40mm down graded) to attain a 28 days cylinder strength of 10.5 N/mm ² including grading, washing shingles, mixing, laying in forms, consolidation, curing for at least 21 days, including preparation of platform, shuttering and stacking in measurable stacks etc. complete including supply of all materials (steel shutter to be used) as per direction of Engineer in charge.	each
40-210-04	Block Size: 60cmx60cmx40cm.	each
40-210-05	Block Size: 50cmx50cmx30cm.	each
40-210-06	Block Size: 40cmx40cmx30cm.	each
40-210-10	Block Size: 60cmx60cmx60cm.	each
40-210-15	Block Size: 50cmx50cmx50cm.	each
40-210-20	Block Size: 50cmx50cmx40cm.	each
40-210-25	Block Size: 45cmx45cmx45cm.	each
40-210-30	Block Size: 45cmx45cmx30cm.	each
40-210-35	Block Size: 40cmx40cmx40cm.	each
40-210-40	Block Size: 40cmx40cmx20cm.	each
40-210-45	Block Size: 35cmx35cmx35cm.	each
40-210-50	Block Size: 30cmx30cmx30cm.	each
40-210-55	Block Size: 30cmx30cmx15cm.	each
40-210-60	Block Size: 25cmx25cmx25cm.	each
40-210-65	Block Size: 20cmx20cmx20cm.	each
40-210-70	Block Size: 45cmx45cmx20cm.	each
40-210-75	Block Size: 40cmx40cmx15cm.	each
40-210-80	Block Size: 50cmx50cmx60cm.	each
40-210-85	Block Size: 50cmx50cmx25cm.	each
40-210-90	Block Size: 50cmx50cmx20cm.	each
40-210-95	Block Size: 40cmx40cmx15cm.	each
40-220	Labour charge for protective works in laying CC blocks of different sizes including preparation of base, watering and ramming of base etc. complete as per direction of Engineer in charge.	cum
40-220-10	Within 200 m.	cum

ITEM DEFINITION REPORT

ItemCode	Item Description	Unit Meas.
40-220-20	Beyond 200 m.	cum
40-230	Manufacturing and supplying C.C. blocks in leanest mix. 1:2:4 with cement, sand (FM \geq 1.5) and Stone Chips (40mm down graded) to attain a 28 days cylinder strength of 15 N/mm ² including grading, washing stone chips, mixing, laying in forms, consolidation, curing for at least 21 days, including preparation of platform, shuttering and stacking in measurable stacks etc. complete including supply of all materials (steel shutter to be used) as per direction of Engineer in charge.	each
40-230-01	Block Size: 100cmx80cmx60cm.	each
40-230-02	Block Size: 90cmx90cmx60cm.	each
40-230-03	Block Size: 75cmx75cmx75cm.	each
40-230-04	Block Size: 60cmx60cmx40cm.	each
40-230-05	Block Size: 50cmx50cmx30cm.	each
40-230-06	Block Size: 40cmx40cmx30cm.	each
40-230-10	Block Size: 60cmx60cmx60cm.	each
40-230-15	Block Size: 50cmx50cmx50cm.	each
40-230-20	Block Size: 50cmx50cmx40cm.	each
40-230-25	Block Size: 45cmx45cmx45cm.	each
40-230-30	Block Size: 45cmx45cmx30cm.	each
40-230-35	Block Size: 40cmx40cmx40cm.	each
40-230-40	Block Size: 40cmx40cmx20cm.	each
40-230-45	Block Size: 35cmx35cmx35cm.	each
40-230-50	Block Size: 30cmx30cmx30cm.	each
40-230-55	Block Size: 30cmx30cmx15cm.	each
40-230-60	Block Size: 25cmx25cmx25cm.	each
40-230-65	Block Size: 20cmx20cmx20cm.	each
40-230-70	Block Size: 45cmx45cmx20cm.	each
40-230-75	Block Size: 40cmx40cmx15cm.	each
40-230-80	Block Size: 50cmx50cmx60cm.	each
40-230-85	Block Size: 50cmx50cmx25cm.	each
40-230-90	Block Size: 50cmx50cmx20cm.	each

ITEM DEFINITION REPORT

ItemCode	Item Description	Unit Meas.
40-230-95	Block Size: 40cmx40cmx15cm.	each
40-235	Manufacturing and supplying C.C. blocks in leanest mix. 1:2:4 with cement, sand (FM \geq 1.5) and Shingles (40mm down graded) to attain a 28 days cylinder strength of 15 N/mm ² including grading, washing stone chips, mixing, laying in forms, consolidation, curing for at least 21 days, including preparation of platform, shuttering and stacking in measurable stacks etc. complete including supply of all materials (steel shutter to be used) as per direction of Engineer in charge.	each
40-235-01	Block Size: 100cmx80cmx60cm.	each
40-235-02	Block Size: 90cmx90cmx60cm.	each
40-235-03	Block Size: 75cmx75cmx75cm.	each
40-235-04	Block Size: 60cmx60cmx40cm.	each
40-235-05	Block Size: 50cmx50cmx30cm.	each
40-235-06	Block Size: 40cmx40cmx30cm.	each
40-235-10	Block Size: 60cmx60cmx60cm.	each
40-235-15	Block Size: 50cmx50cmx50cm.	each
40-235-20	Block Size: 50cmx50cmx40cm.	each
40-235-25	Block Size: 45cmx45cmx45cm.	each
40-235-30	Block Size: 45cmx45cmx30cm.	each
40-235-35	Block Size: 40cmx40cmx40cm.	each
40-235-40	Block Size: 40cmx40cmx20cm.	each
40-235-45	Block Size: 35cmx35cmx35cm.	each
40-235-50	Block Size: 30cmx30cmx30cm.	each
40-235-55	Block Size: 30cmx30cmx15cm.	each
40-235-60	Block Size: 25cmx25cmx25cm.	each
40-235-65	Block Size: 20cmx20cmx20cm.	each
40-235-70	Block Size: 45cmx45cmx20cm.	each
40-235-75	Block Size: 40cmx40cmx15cm.	each
40-235-80	Block Size: 50cmx50cmx60cm.	each
40-235-85	Block Size: 50cmx50cmx25cm.	each
40-235-90	Block Size: 50cmx50cmx20cm.	each

ITEM DEFINITION REPORT

ItemCode	Item Description	Unit Meas.
40-235-95	Block Size: 40cmx40cmx15cm.	each
40-240	Manufacturing and supplying C.C. blocks in leanest mix. 1:2:4 with cement, sand (FM \geq 2.0) and Stone Chips (40mm down graded) to attain a 28 days cylinder strength of 18 N/mm ² including grading, washing stone chips, mixing, laying in forms, consolidation, curing for at least 21 days, including preparation of platform, shuttering and stacking in measurable stacks etc. complete including supply of all materials (steel shutter to be used) as per direction of Engineer in charge.	each
40-240-01	Block Size: 100cmx80cmx60cm.	each
40-240-02	Block Size: 90cmx90cmx60cm.	each
40-240-03	Block Size: 75cmx75cmx75cm.	each
40-240-04	Block Size: 60cmx60cmx40cm.	each
40-240-05	Block Size: 50cmx50cmx30cm.	each
40-240-06	Block Size: 40cmx40cmx30cm.	each
40-240-10	Block Size: 60cmx60cmx60cm.	each
40-240-15	Block Size: 50cmx50cmx50cm.	each
40-240-20	Block Size: 50cmx50cmx40cm.	each
40-240-25	Block Size: 45cmx45cmx45cm.	each
40-240-30	Block Size: 45cmx45cmx30cm.	each
40-240-35	Block Size: 40cmx40cmx40cm.	each
40-240-40	Block Size: 40cmx40cmx20cm.	each
40-240-45	Block Size: 35cmx35cmx35cm.	each
40-240-50	Block Size: 30cmx30cmx30cm.	each
40-240-55	Block Size: 30cmx30cmx15cm.	each
40-240-60	Block Size: 25cmx25cmx25cm.	each
40-240-65	Block Size: 20cmx20cmx20cm.	each
40-240-70	Block Size: 45cmx45cmx20cm.	each
40-240-75	Block Size: 40cmx40cmx15cm.	each
40-240-80	Block Size: 50cmx50cmx60cm.	each
40-240-85	Block Size: 50cmx50cmx25cm.	each
40-240-90	Block Size: 50cmx50cmx20cm.	each

ITEM DEFINITION REPORT

ItemCode	Item Description	Unit Meas.
40-240-95	Block Size: 40cmx40cmx15cm.	each
40-245	Manufacturing and supplying C.C. blocks in leanest mix. 1:2:4 with cement, sand (FM>=2.0) and Shingles (40mm down graded) to attain a 28 days cylinder strength of 18 N/mm ² including grading, washing stone shingles, mixing, laying in forms, consolidation, curing for at least 21 days, including preparation of platform, shuttering and stacking in measurable stacks etc. complete including supply of all materials (steel shutter to be used) as per direction of Engineer in charge.	each
40-245-01	Block Size: 100cmx80cmx60cm.	each
40-245-02	Block Size: 90cmx90cmx60cm.	each
40-245-03	Block Size: 75cmx75cmx75cm.	each
40-245-04	Block Size: 60cmx60cmx40cm.	each
40-245-05	Block Size: 50cmx50cmx30cm.	each
40-245-06	Block Size: 40cmx40cmx30cm.	each
40-245-10	Block Size: 60cmx60cmx60cm.	each
40-245-15	Block Size: 50cmx50cmx50cm.	each
40-245-20	Block Size: 50cmx50cmx40cm.	each
40-245-25	Block Size: 45cmx45cmx45cm.	each
40-245-30	Block Size: 45cmx45cmx30cm.	each
40-245-35	Block Size: 40cmx40cmx40cm.	each
40-245-40	Block Size: 40cmx40cmx20cm.	each
40-245-45	Block Size: 35cmx35cmx35cm.	each
40-245-50	Block Size: 30cmx30cmx30cm.	each
40-245-55	Block Size: 30cmx30cmx15cm.	each
40-245-60	Block Size: 25cmx25cmx25cm.	each
40-245-65	Block Size: 20cmx20cmx20cm.	each
40-245-70	Block Size: 45cmx45cmx20cm.	each
40-245-75	Block Size: 40cmx40cmx15cm.	each
40-245-80	Block Size: 50cmx50cmx60cm.	each
40-245-85	Block Size: 50cmx50cmx25cm.	each
40-245-90	Block Size: 50cmx50cmx20cm.	each

ITEM DEFINITION REPORT

ItemCode	Item Description	Unit Meas.
40-245-95	Block Size: 40cmx40cmx15cm.	each
40-250	Manufacturing and supplying of brick blocks with first class brick in cement mortar (1:4), with sand of FM \geq 1.5, including soaking, cleaning bricks properly, curing for at least 14 days, stacking at site etc. complete with supply of all materials and as per direction of Engineer in charge:	each
40-250-10	block size 63cmx63cmx38cm.	each
40-250-20	block size 63cmx63cmx30cm.	each
40-250-30	block size 50cmx50cmx38cm.	each
40-250-40	block size 50cmx50cmx30cm.	each
40-250-50	block size 50cmx50cmx15cm.	each
40-250-60	block size 38cmx38cmx30cm.	each
40-250-65	block size 38cmx38cmx22cm	each
40-250-70	block size 38cmx38cmx15cm.	each
40-250-80	block size 25cmx25cmx22cm.	each
40-270	Labour charge for placing brick blocks of all sizes, including preparation of base, ramming, watering etc. complete and including carriage within the site of the sluice or any protective work as per direction of Engineer in charge.	cum
40-270-10	Within 200 m.	cum
40-270-20	Beyond 200 m.	cum
40-280	Supplying local hard rock (Maddhapara, mini. unit weight of 2700 kg/cum) at work site including all modes of carriages, handling, loading, unloading and stacking in measurable stacks as per specified size ranges including all taxes etc complete (deduction for voids will be made at the rate mentioned against each size range for arriving at actual volume) as per direction of Engineer in Charge.	cum
40-280-10	10cm to 15cm size; void 10 %	cum
40-280-20	15cm to 22cm size; void 12 %	cum
40-280-30	22cm to 30cm size; void 15 %	cum
40-280-40	30cm to 45cm size; void 20 %	cum
40-280-50	45cm to 60cm size ; void 20 %	cum
40-280-60	60cm and above size ; void 20 %	cum

ITEM DEFINITION REPORT

ItemCode	Item Description	Unit Meas.
40-290	Supply of local hard stone/boulders at work site including all modes carriages, handling, loading, unloading and stacking in measurable stacks as per specific size ranges, including all taxes etc. complete (deduction for voids will be made at the rate mentioned against each size range for arriving at actual volume) as per direction of Engineer in charge.	cum
40-290-10	10.0 cm to 15.0 cm size, void 8.5%.	cum
40-290-20	15.0 cm to 22.0 cm size, void 10%.	cum
40-290-30	22.0 cm to 30.0 cm size, void 10%.	cum
40-290-40	30.0 cm to 45.0 cm size, void 12%.	cum
40-290-50	45.0 cm and above size, void 15%.	cum
40-300	Labour charge for protective works in laying stone/hard rock/ boulders of different sizes from 15cm to 50 cm including preparation of base and levelling, dressing etc. complete as per direction of Engineer in charge.	cum
40-300-10	Within 200 m.	cum
40-300-20	Beyond 200 m.	cum
40-320	Labour charge for dumping in position Hard rock/ stone/ boulders/C.C blocks/brick blocks/sand cement blocks of different sizes on river bed/slope beyond 1.00m depth of water by boat or any other means as per direction of Engineer in charge.	cum
40-320-10	Within 200 m.	cum
40-320-20	Beyond 200 m.	cum
40-330	Labour charge for salvaging of cement concrete/sand cement/brick blocks of different sizes including carriage within the site of any protective work with all leads and lifts and stacking in measurable stacks as per direction of Engineer in charge.	cum
40-340	Labour charge for salvaging of Geo-Bags of different sizes including carriage within the site of any protective work with all leads and lifts and stacking in measurable stacks as per direction of Engineer in charge.	No.
40-340-10	Salvaging of 250 kg geo-bag	No.
40-340-15	Salvaging of 200 kg geo-bag	No.
40-340-20	Salvaging of 175 kg geo-bag	No.
40-340-30	Salvaging of 125 kg geo-bag	No.
40-340-40	Salvaging of 110 kg geo-bag	No.
40-340-50	Salvaging of 80 kg geo-bag	No.

ITEM DEFINITION REPORT

ItemCode	Item Description	Unit Meas.
40-350	Supplying and dumping/laying in position 2nd class brick bats of specified sizes (not less than 1/3rd brick) on bed, slopes or any other places by any means as per direction of Engineer in charge.	cum
40-400	Supplying new gunny bags at site :	nos.
40-400-10	Capacity 50 kg.	no
40-400-20	Capacity 75 kg.	no
40-410	Supplying 2nd hand gunny bags in good condition at site :	nos
40-410-10	Capacity 50 kg.	no
40-410-20	Capacity 75 kg.	no
40-415	Supplying new Synthetic bags at site :	no
40-415-10	Capacity 50 kg.	no
40-415-20	Capacity 75 kg.	no
40-420	Labour charge for filling empty gunny or synthetic bags with sand or earth, sewing the end with sutly, including carrying and placing in above water position within the site as per direction of Engineer in charge.	nos
40-420-10	Capacity 50 kg (Fill volume = 0.030 cum).	no
40-420-20	Capacity 75 kg (Fill volume = 0.040 cum).	no
40-430	Labour charge for filling empty gunny or synthetic bags with sand or earth, sewing the end with sutly, including carring and placing under water position within the site as per direction of Engineer -in-Charge.	
40-430-10	Capacity : 50 kg (Fill Volume = 0.030 cum)	no
40-430-20	Capacity : 75 kg (Fill Volume = 0.040 cum)	no
40-440	Supplying and filling empty gunny/synthetic bags as approved in design & drawing with sand/ earth available at site sewing the end with sutly, including carrying and placing in position within the site with supply of all materials as per direction of Engineer in charge.	nos
40-440-10	Capacity : 50 kg (New gunny bags)	no
40-440-20	Capacity : 50 kg (2nd hand gunny bags)	no
40-440-30	Capacity : 50 kg (Synthetic bag)	no
40-440-40	Capacity : 75 kg (New gunny bags)	no
40-440-50	Capacity : 75 kg (2nd hand gunny bags)	no
40-440-60	Capacity : 75 kg (New synthetic bags)	no

ITEM DEFINITION REPORT

ItemCode	Item Description	Unit Meas.
40-450	Supplying and filling empty gunny/ synthetic bags as approved in design and drawing with sand of FM \geq 0.80, sewing the end with sutly, including carrying and placing in position within the site with supply of all materials as per direction of Engineer in charge.	nos
40-450-10	Capacity : 50 kg (New gunny bags)	no
40-450-20	Capacity : 50 kg (2nd hand gunny bags)	no
40-450-30	Capacity : 50 kg. (Synthetic bag)	no
40-450-40	Capacity : 75 kg (New gunny bags)	no
40-450-50	Capacity : 75 kg (2nd hand gunny bags)	no
40-450-60	Capacity : 75 kg (New synthetic bags)	no
40-460	Protective work with sand cement (10:1 proportion) filled 3/4th in 50 kg gunny bags, including supply of all materials and necessary sewing, filling and placing in position as per specification and direction of Engineer in charge.	nos
40-460-10	In new gunny bags (Fill volume = 0.026 cum).	no
40-460-20	In 2nd hand gunny bags (Fill volume = 0.026 cum).	no
40-470	Protective work with sand cement (8:1 propotion) filled 3/4th in 50 Kg & 75Kg gunny bags (sand F.M \geq 1.00) including supply of all materials and necessaary sewing, filling and placiing/dumping in position and mixing with mixture machine with desined water cement ratio & curing as per specification and direction of the Engineer-in-charge.	no
40-470-10	Sand cement new gunny bag (50 Kg; sand cement 8:1; Fill vol = 0.026 cum)	no
40-470-20	Sand cement 2nd hand gunny bag (50 Kg; sand cement 8:1; Fill vol.= 0.026 cum)	no
40-470-30	Sand cement new gunny bag (75 Kg; sand cement 8:1; Fill vol = 0.031 cum)	no
40-470-40	Sand cement 2nd hand gunny bag (75 Kg; sand cement 8:1; Fill vol = 0.031 cum)	no
40-480	Protective work with sand cement (6:1 propotion) filled 3/4th in 75Kg gunny bags (sand F.M \geq 1.00) including supply of all materials and necessaary sewing, filling and placiing/dumping in position and mixing with mixture machine with desined water cement ratio & curing as per specification and direction of the Engineer-in-charge.	no
40-480-30	Sand cement new gunny bag (75 Kg; sand cement 6:1; Fill vol = 0.031 cum)	no

ITEM DEFINITION REPORT

ItemCode	Item Description	Unit Meas.
40-482	[Geo-textile bag filled with sand cement mixture] Supplying filling and placing of geo-textile bags of different sizes and capacity at project/work site, making with standard geo-textile fabric (100% Polypropylene fabric, mass \geq 400gm/m ² , unit weight : 855 Kg/m ³ to 946 Kg/m ³ , EOS \leq 0.07 mm) and sewing in accordance with the drawing and Technical Specifications of BWDB and Schedule of Rates of BWDB, filling with sand-cement mixed (6:1 Proportion, sand: F.M = 1.00, Portland cement) , sewing along one transverse (top) side after filling, staking in measurable/countable stakes, marking by synthetic enamel paint during counting, placing in position as per approved drawing including levelling, dressing and preparation of base, cost of all materials & equipments and its mobilization, labour, incidental charges etc. complete as per technical specification, approved design and direction of Engineer in charge.	no
40-482-10	Geo-bag; inner size:950mmx750mm, outer size:1000mmx800mm geo-fabric th. \Rightarrow 3.0mm, Fill Vol: 0.0840cum; wt: 125kg	no
40-482-20	Geo-bag; inner size:1075mmx850mm, outer size:1125mmx900mm geo-fabric th. \Rightarrow 3.0mm, Fill Vol: 0.1164cum; wt: 175kg	no
40-484	Supplying , filling and placing of Geo-Tube, making with standard geo-textile (100% Polypropylene fabric, unit weight : 855 Kg/m ³ to 946 Kg/m ³ , geo-textile thickness = 4.00 mm, mass = 550 gm/m ²) and sewing in accordance with the detailed drawing and Technical Specifications included in the Tender Document and Schedule of Rates of BWDB, filling hydraulically with Sand (minimum 95% sand must be retained on sieve no 200), sewing along one transverse (top) side after filling, including carrying, placing in position in the site as per approved design, cost of all materials & equipments and its mobilization, labour, incidental charges etc. complete as per direction of Engineer in Charge.	m
40-484-10	Geo Tube: Diameter= 2.5 m	m
40-484-20	Geo Tube: Diameter= 1.25 m	m
40-485	Supplying of geo-textile bags (empty) of different sizes and capacity at project/work site, making the bag with standard Geo-Textile fabric (100% Polypropylene Fabric, mass \geq 400gm/m ² , unit weight : 855 Kg/m ³ to 946 Kg/m ³ , EOS \leq 0.07 mm) and sewing in accordance with the detailed drawing and Technical Specifications included in the Tender Document and Schedule of Rates of BWDB, protecting the geo-textile bags form UV ray or any other damages including cost of all materials, labours, incidental charges etc. complete as per direction of Engineer in charge.	no
40-485-10	Geo-bag; inner size:1200mmx950mm, outer size:1250mmx1000mm, geo-fabric th. \Rightarrow 3.0mm, Fill Vol: 0.1664cum; wt: 250kg	no
40-485-15	Geo-bag; inner size:1100mmx850mm, outer size:1150mmx900mm, geo-fabric th. \Rightarrow 3.0mm, Fill Vol: 0.1333cum; wt: 200kg	no
40-485-20	Geo-bag; inner size:1075mmx850mm, outer size:1125mmx900mm geo-fabric th. \Rightarrow 3.0mm, Fill Vol: 0.1164cum; wt: 175kg	no

ITEM DEFINITION REPORT

ItemCode	Item Description	Unit Meas.
40-485-30	Geo-bag; inner size:950mmx750mm, outer size:1000mmx800mm geo-fabric th.=>3.0mm, Fill Vol: 0.0840cum; wt: 125kg	no
40-485-40	Geo-bag; inner size:900mmx700mm, outer size:950mmx750mm, geo-fabric th.=>3.0mm, Fill Vol: 0.0730cum; wt: 110kg	no
40-485-50	Geo-bag; inner size:800mmx650mm, outer size:850mmx700mm, geo-fabric th.=>3.0mm, Fill Vol: 0.0520cum; wt: 80kg	no
40-486	Supplying of geo-textile bags (empty) of different sizes and capacity at project/work site, making the bag with standard Geo-Textile fabric (100% Polypropylene fabric, mass>= 300gm/m ² , unit weight : 855 Kg/m ³ to 946 Kg/m ³ , EOS<=0.07 mm) and sewing in accordance with the detailed drawing and Technical Specifications included in the Tender Document and Schedule of Rates of BWDB, protecting the geo-textile bags form UV ray or any other damages including cost of all materials, labours, incidental charges etc. complete as per direction of Engineer in charge.	no
40-486-20	Geo-bag; inner size:1075mmx850mm, outer size:1125mmx900mm geo-fabric th.=>2.0mm, Fill Vol: 0.1164cum; wt: 175kg	no
40-486-30	Geo-bag; inner size:950mmx750mm, outer size:1000mmx800mm geo-fabric th.=>2.0mm, Fill Vol: 0.0840cum; wt: 125kg	no
40-487	[Dumping with Barge & Total Station] Filling and dumping of geo-textile bags of different sizes and capacity at project/work site, protecting from UV ray or any other damages, filling with sand (dry and minimum 95% sand must be retained on sieve no 200), sewing along one transverse (top) side after filling, staking in measurable/countable stakes, marking with synthetic enamel paint during counting, dumping from properly positioned and anchored flat top barge/pontoon over an area as per drawing, maintaining & recording the dumping position of the barge/pontoon using total station including loading, unloading, sequential piling of geo-bags on the dumping edge of barge/pontoon, cost of all materials & equipments and its mobilization, labour, incidental charges, etc. complete as per technical specification, approved design and direction of Engineer in charge. [fill volume and weight will be measured after filling with dry sand]	no
40-487-10	Geo-bag; inner size:1200mmx950mm, outer size:1250mmx1000mm,, Fill Vol: 0.1664cum; wt: 250kg	no
40-487-15	Geo-bag; inner size:1100mmx850mm, outer size:1150mmx900mm,, Fill Vol: 0.1333cum; wt: 200kg	no
40-487-20	Geo-bag; inner size:1075mmx850mm, outer size:1125mmx900mm, Fill Vol: 0.1164cum; wt: 175kg	no
40-487-30	Geo-bag; inner size:950mmx750mm, outer size:1000mmx800mm, Fill Vol: 0.0840cum; wt: 125kg	no
40-487-40	Geo-bag; inner size:900mmx700mm, outer size:950mmx750mm,, Fill Vol: 0.0730cum; wt: 110kg	no

ITEM DEFINITION REPORT

ItemCode	Item Description	Unit Meas.
40-487-50	Geo-bag; inner size:800mmx650mm, outer size:850mmx700mm,, Fill Vol: 0.0520cum; wt: 80kg	no
40-488	[Dunping with Boat & Total Station] Filling and dumping of geo-textile bags of different sizes and capacity at project/work site, protecting the geotextile bags from UV ray or any other damages, filling with sand (dry and minimum 95% sand must be retained on sieve no 200), sewing along one transverse (top) side after filling, staking in measurable/countable stakes, marking with synthetic enamel paint during counting, dumping from properly positioned and anchored flat top engine boat over an area as per drawing, maintaining & recording the dumping position of the boat by using total station including loading, unloading, sequential piling of geo-bags on the dumping edge of boat, carrying geo-bags from stake-yard to dumping place by head load and power driven flat top country boat, cost of all materials & equipments and its mobilization, labour, incidental charges etc. complete as per technical specification, approved design and direction of Engineer in charge. [fill volume and weight will be measured after filling with dry sand]	no
40-488-10	Geo-bag; inner size:1200mmx950mm, outer size:1250mmx1000mm,, Fill Vol: 0.1664cum; wt: 250kg	no
40-488-15	Geo-bag; inner size:1100mmx850mm, outer size:1150mmx900mm,, Fill Vol: 0.1333cum; wt: 200kg	no
40-488-20	Geo-bag; inner size:1075mmx850mm, outer size:1125mmx900mm, Fill Vol: 0.1164cum; wt: 175kg	no
40-488-30	Geo-bag; inner size:950mmx750mm, outer size:1000mmx800mm, Fill Vol: 0.0840cum; wt: 125kg	no
40-488-40	Geo-bag; inner size:900mmx700mm, outer size:950mmx750mm,, Fill Vol: 0.0730cum; wt: 110kg	no
40-488-50	Geo-bag; inner size:800mmx650mm, outer size:850mmx700mm,, Fill Vol: 0.0520cum; wt: 80kg	no
40-489	[For emergency work] Filling and dumping of geo-textile bags of different sizes and capacity at project/work site, protecting the geotextile bags from UV ray or any other damages, filling with sand (dry and minimum 95% sand must be retained on sieve no 200), sewing along one transverse (top) side after filling, staking in measurable/countable stakes, marking with synthetic enamel paint during counting, dumping from properly positioned and anchored flat top engine boat over an area as per drawing including loading, unloading, sequential piling of geo-bags on the dumping edge of boat, cost of all materials & equipments and its mobilization, labour, incidental charges etc. complete as per technical specification, approved design and direction of Engineer in charge. [fill volume and weight will be measured after filling with dry sand]	no
40-489-10	Geo-bag; inner size:1200mmx950mm, outer size:1250mmx1000mm, Fill Vol: 0.1664cum; wt: 250kg	no

ITEM DEFINITION REPORT

ItemCode	Item Description	Unit Meas.
40-489-15	Geo-bag; inner size:1100mmx850mm, outer size:1150mmx900mm, Fill Vol: 0.1333cum; wt: 200kg	no
40-489-20	Geo-bag; inner size:1075mmx850mm, outer size:1125mmx900mm, Fill Vol: 0.1164cum; wt: 175kg	no
40-489-30	Geo-bag; inner size:950mmx750mm, outer size:1000mmx800mm, Fill Vol: 0.0840cum; wt: 125kg	no
40-489-40	Geo-bag; inner size:900mmx700mm, outer size:950mmx750mm,Fill Vol: 0.0730cum; wt: 110kg	no
40-489-50	Geo-bag; inner size:800mmx650mm, outer size:850mmx700mm, Fill Vol: 0.0520cum; wt: 80kg	no
40-490	Filling and placing of geo-textile bags of different sizes and capacity at project/work site, filling with sand (dry and minimum 95% sand must be retained on sieve no 200), sewing along one transverse (top) side after filling sand, staking in measurable/countable stakes, marking with synthetic enamel paint during counting and placing in position as per drawing including levelling, dressing, preparation of base, cost of all materials & equipments and its mobilization, labour, incidental charges etc complete as per technical specification, approved design and direction of Engineer in charge. [fill volume and weight will be measured after filling with dry sand]	No.
40-490-10	Geo-bag; inner size:1200mmx950mm, outer size:1250mmx1000mm, Fill Vol: 0.1664cum; wt: 250kg	No.
40-490-15	Geo-bag; inner size:1100mmx850mm, outer size:1150mmx900mm,, Fill Vol: 0.1333cum; wt: 200kg	No.
40-490-20	Geo-bag; inner size:1075mmx850mm, outer size:1125mmx900mm, Fill Vol: 0.1164cum; wt: 175kg	No.
40-490-30	Geo-bag; inner size:950mmx750mm, outer size:1000mmx800mm, Fill Vol: 0.0840cum; wt: 125kg	No.
40-490-40	Geo-bag; inner size:900mmx700mm, outer size:950mmx750mm, Fill Vol: 0.0730cum; wt: 110kg	No.
40-490-50	Geo-bag; inner size:800mmx650mm, outer size:850mmx700mm, Fill Vol: 0.0520cum; wt: 80kg	No.

ITEM DEFINITION REPORT

ItemCode	Item Description	Unit Meas.
40-491	<p>[Dumping with Barge & Total Station]</p> <p>Supplying, filling and dumping of geo-textile bags of different sizes and capacity at project/work site, making with standard geo-textile fabric (100% Polypropylene Fabric, mass\geq 400gm/m², unit weight : 855 Kg/m³ to 946 Kg/m³, EOS\leq0.07 mm) and sewing in accordance with the drawing and Technical Specifications of BWDB and Schedule of Rates of BWDB, protecting the geotextile bags from UV ray or any other damages, filling with sand (dry and minimum 95% sand must be retained on sieve no 200), sewing along one transverse (top) side after filling, staking in measurable/countable stakes, marking with synthetic enamel paint during counting, dumping from properly positioned and anchored flat top barge/pontoon over an area as per drawing, maintaining & recording the position of dumping barge/pontoon using total station including loading, unloading, sequential piling of geo-bags on the dumping edge of barge/pontoon, cost of all materials & equipments and its mobilization, labour, incidental charges etc. complete as per technical specification, approved design and direction of Engineer in charge. [fill volume and weight will be measured after filling with dry sand]</p>	No.
40-491-10	Geo-bag; inner size:1200mmx950mm, outer size:1250mmx1000mm, geo-fabric th. \geq 3.0mm, Fill Vol: 0.1664cum; wt: 250kg	No.
40-491-15	Geo-bag; inner size:1100mmx850mm, outer size:1150mmx900mm, geo-fabric th. \geq 3.0mm, Fill Vol: 0.1333cum; wt: 200kg	No.
40-491-20	Geo-bag; inner size:1075mmx850mm, outer size:1125mmx900mm geo-fabric th. \geq 3.0mm, Fill Vol: 0.1164cum; wt: 175kg	No.
40-491-30	Geo-bag; inner size:950mmx750mm, outer size:1000mmx800mm geo-fabric th. \geq 3.0mm, Fill Vol: 0.0840cum; wt: 125kg	No.
40-491-40	Geo-bag; inner size:900mmx700mm, outer size:950mmx750mm, geo-fabric th. \geq 3.0mm, Fill Vol: 0.0730cum; wt: 110kg	No.
40-491-50	Geo-bag; inner size:800mmx650mm, outer size:850mmx700mm, geo-fabric th. \geq 3.0mm, Fill Vol: 0.0520cum; wt: 80kg	No.

ITEM DEFINITION REPORT

ItemCode	Item Description	Unit Meas.
40-492	<p>[Dumping with Boat & Total Station]</p> <p>Supplying, filling and dumping of geo-textile bags of different sizes and capacity at project/work site, making with standard geo-textile fabric (100% Polypropylene fabric, mass\geq 400gm/m², unit weight : 855 Kg/m³ to 946 Kg/m³, EOS\leq0.07 mm) and sewing in accordance with the drawing and Technical Specifications of BWDB and Schedule of Rates of BWDB, protecting the geotextile bags from UV ray or any other damages, filling with sand (dry and minimum 95% sand must be retained on sieve no 200), sewing along one transverse (top) side after filling, staking in measurable/countable stakes, marking by synthetic enamel paint during counting, dumping from properly positioned and anchored flat top engine boat over an area as per drawing, maintaining & recording the position of dumping boat using total station including loading, unloading, sequential piling of geo-bags on the dumping edge of boat, carrying geo-bags from stake-yard to dumping place by head load and power driven flat top country boat, cost of all materials & equipments and its mobilization, labour, incidental charges etc complete as per technical specification, approved design and direction of Engineer in charge. [fill volume and weight will be measured after filling with dry sand]</p>	No.
40-492-10	Geo-bag; inner size:1200mmx950mm, outer size:1250mmx1000mm, geo-fabric th. \geq 3.0mm, Fill Vol: 0.1664cum; wt: 250kg	No.
40-492-15	Geo-bag; inner size:1100mmx850mm, outer size:1150mmx900mm, geo-fabric th. \geq 3.0mm, Fill Vol: 0.1333cum; wt: 200kg	No.
40-492-20	Geo-bag; inner size:1075mmx850mm, outer size:1125mmx900mm geo-fabric th. \geq 3.0mm, Fill Vol: 0.1164cum; wt: 175kg	No.
40-492-30	Geo-bag; inner size:950mmx750mm, outer size:1000mmx800mm geo-fabric th. \geq 3.0mm, Fill Vol: 0.0840cum; wt: 125kg	No.
40-492-40	Geo-bag; inner size:900mmx700mm, outer size:950mmx750mm, geo-fabric th. \geq 3.0mm, Fill Vol: 0.0730cum; wt: 110kg	No.
40-492-50	Geo-bag; inner size:800mmx650mm, outer size:850mmx700mm, geo-fabric th. \geq 3.0mm, Fill Vol: 0.0520cum; wt: 80kg	No.

ITEM DEFINITION REPORT

ItemCode	Item Description	Unit Meas.
40-493	<p>[For Emergency work]</p> <p>Supplying, filling and dumping of geo-textile bags of different sizes and capacity at project/work site, making with standard geo-textile fabric (100% Polypropylene fabric, mass\geq 400gm/m², unit weight : 855 Kg/m³ to 946 Kg/m³, EOS\leq0.07 mm) and sewing in accordance with the drawing and Technical Specifications of BWDB and Schedule of Rates of BWDB, protecting the geotextile bags from UV ray or any other damages, filling with sand (dry and minimum 95% sand must be retained on sieve no 200), sewing along one transverse (top) side after filling, staking in measurable/countable stakes, marking by synthetic enamel paint during counting, dumping from properly positioned and anchored flat top engine boat over an area as per drawing including loading, unloading, sequential piling of geo-bags on the dumping edge of boat, cost of all materials & equipments and its mobilization, labour, incidental charges etc. complete as per technical specification, approved design and direction of Engineer in charge.</p> <p>[fill volume and weight will be measured after filling with dry sand]</p>	No.
40-493-10	Geo-bag; inner size:1200mmx950mm, outer size:1250mmx1000mm, geo-fabric th. \geq 3.0mm, Fill Vol: 0.1664cum; wt: 250kg	No.
40-493-15	Geo-bag; inner size:1100mmx850mm, outer size:1150mmx900mm, geo-fabric th. \geq 3.0mm, Fill Vol: 0.1333cum; wt: 200kg	No.
40-493-20	Geo-bag; inner size:1075mmx850mm, outer size:1125mmx900mm geo-fabric th. \geq 3.0mm, Fill Vol: 0.1164cum; wt: 175kg	No.
40-493-30	Geo-bag; inner size:950mmx750mm, outer size:1000mmx800mm geo-fabric th. \geq 3.0mm, Fill Vol: 0.0840cum; wt: 125kg	No.
40-493-40	Geo-bag; inner size:900mmx700mm, outer size:950mmx750mm, geo-fabric th. \geq 3.0mm, Fill Vol: 0.0730cum; wt: 110kg	No.
40-493-50	Geo-bag; inner size:800mmx650mm, outer size:850mmx700mm, geo-fabric th. \geq 3.0mm, Fill Vol: 0.0520cum; wt: 80kg	No.
40-494	<p>Supplying filling and placing of geo-textile bags of different sizes and capacity at project/work site, making with standard geo-textile fabric (100% Polypropylene fabric, mass\geq 400gm/m², unit weight : 855 Kg/m³ to 946 Kg/m³, EOS\leq0.07 mm) and sewing in accordance with the drawing and Technical Specifications of BWDB and Schedule of Rates of BWDB, filling with sand (dry and minimum 95% sand must be retained on sieve no 200), sewing along one transverse (top) side after filling, staking in measurable/countable stakes, marking by synthetic enamel paint during counting, placing in position as per approved drawing including levelling, dressing and preparation of base, cost of all materials & equipments and its mobilization, labour, incidental charges etc. complete as per technical specification, approved design and direction of Engineer in charge.</p> <p>[fill volume and weight will be measured after filling with dry sand]</p>	No.
40-494-10	Geo-bag; inner size:1200mmx950mm, outer size:1250mmx1000mm, geo-fabric th. \geq 3.0mm, Fill Vol: 0.1664cum; wt: 250kg	No.

ITEM DEFINITION REPORT

ItemCode	Item Description	Unit Meas.
40-494-15	Geo-bag; inner size:1100mmx850mm, outer size:1150mmx900mm, geo-fabric th.=>3.0mm, Fill Vol: 0.1333cum; wt: 200kg	No.
40-494-20	Geo-bag; inner size:1075mmx850mm, outer size:1125mmx900mm geo-fabric th.=>3.0mm, Fill Vol: 0.1164cum; wt: 175kg	No.
40-494-30	Geo-bag; inner size:950mmx750mm, outer size:1000mmx800mm geo-fabric th.=>3.0mm, Fill Vol: 0.0840cum; wt: 125kg	No.
40-494-40	Geo-bag; inner size:900mmx700mm, outer size:950mmx750mm, geo-fabric th.=>3.0mm, Fill Vol: 0.0730cum; wt: 110kg	No.
40-494-50	Geo-bag; inner size:800mmx650mm, outer size:850mmx700mm, geo-fabric th.=>3.0mm, Fill Vol: 0.0520cum; wt: 80kg	No.
40-500	Supplying, sizing and placing in position local hard wood bullah such as Sonali gul, Tetul, Jam etc. including all taxes and incidental charges (bullah measured at 1/3rd. length from thick end excluding the bark) etc. complete as per direction of Engineer in charge.	m
40-500-10	10 cm to 13 cm	m
40-500-20	Above 13 cm to 15 cm	m
40-500-30	Above 15 cm to 18 cm	m
40-500-40	Above 18 cm to 20 cm	m
40-500-50	Above 20 cm to 23 cm	m
40-500-60	Above 23 cm.	m
40-510	Labour charge for driving local hard bullah such as Sonali gul, Tetul, Jam etc. bullah piles on dry land, by monkey hammer etc. complete including charges for all equipments as per direction of Engineer in charge.	m
40-510-10	10 cm to 13 cm	m
40-510-20	Above 13 cm to 15 cm	m
40-510-30	Above 15 cm to 18 cm	m
40-510-40	Above 18 cm to 20 cm	m
40-510-50	Above 20 cm to 23 cm	m
40-510-60	Above 23 cm.	m
40-520	Labour charge for driving hard wood bullah, such as Sonali gul, Tetul, Jam etc. bullah piles in water by monkey hammer, including supplying and erection of all necessary staging boat derricks and other equipments, etc. complete as per direction of Engineer in charge:	m
40-520-10	10 cm to 13 cm	m

ITEM DEFINITION REPORT

ItemCode	Item Description	Unit Meas.
40-520-20	Above 13 cm to 15 cm	m
40-520-30	Above 15 cm to 18 cm	m
40-520-40	Above 18 cm to 20 cm	m
40-520-50	Above 20 cm to 23 cm	m
40-520-60	Above 23 cm.	m
40-530	Supplying, fitting and fixing of half sawn local hard wood walling pieces, fitted with 20mm. dia bolts and nuts at 1.0m c/c etc. complete as per directoin of Engineer in charge:	m
40-530-05	13 cm to 15 cm dia	m
40-530-10	15 cm to 18 cm dia	m
40-530-20	Above 18 cm dia	m
40-540	Supplying, sizing and placing of barrack bamboo pins and stays of diameter \geq 8.0 cm in position etc. complete as per direction of Engineer in charge.	no
40-540-10	Length: \geq 4.5 m to \leq 6.0 m.	no
40-540-20	Length: \geq 2.0 m to $<$ 4.5 m.	no
40-550	Labour charge for driving barrack bamboo pins of diameter \geq 8.0 cm, by hammer or monkey hammer, as per direction of Engineer in charge.	m
40-550-10	\geq 1.50 m to \leq 2.0 m drive, on dry land.	m
40-550-20	\geq 1.50 m to \leq 2.0 m drive, in water including necessary staging etc. as required.	m
40-550-30	\geq 0.75 m to $<$ 1.50 m, on dry land.	m
40-550-40	\geq 0.75 m to $<$ 1.50 m, in water including necessary staging etc. as required.	m
40-560	Supplying, sizing and fitting in position 8.0 cm and above dia in size full barrack bamboo half split walling pieces with nails average 1.00 m apart including supply of all materials as per direction of Engineer in charge.	m
40-560-10	Double Walling.	m
40-560-20	Single Walling.	m
40-570	Labour charge for taking out bullah from river bed (measurement for the driven portion to be taken only); or cross ties walling pieces, including cutting and opening out bolts and nuts; or old bamboo pieces and struts from river bed and stacking the materials on the bank as per direction of Engineer in charge.	m
40-570-10	Bullah	m
40-570-20	Walling pieces	m

ITEM DEFINITION REPORT

ItemCode	Item Description	Unit Meas.
40-570-30	Old bamboo pieces and struts	no
40-580	Supplying and placing in position and fitting, fixing single layer tarjah doubly woven matting with necessary ties including the cost of all materials etc. complete as per direction of Engineer in charge.	sqm
40-590	Supplying, fitting and fixing old drum sheet with necessary nails,ties etc. for protective works, including carriage of all materials to work site, as per direction of Engineer in charge.	sqm
40-600	Supplying and placing non-woven needle punched type geotextile fabric (100% Polypropylene Fabric, unit weight : 855 Kg/m ³ to 946 Kg/m ³) as filter materials of elongation at maximum force machine direction (MD) $\geq 60\%$ and $\leq 100\%$, elongation at maximum force (CMD) $\Rightarrow 40\%$ and $\leq 100\%$,horizontal and vertical permeability (under 2 kn/m ² pressure) $\Rightarrow 2 \times 10^{-3}$ m/sec. for effective erosion protection in hydraulic structures/river training works including local handling, placing in position, providing machine seamed joints (with 100% polypropylene or nylon thread) or 35cm lap in dry condition or minimum 100cm lap under water including protecting the geotextile material from UV ray and from any other damages including supply of all materials, labours, equipment's etc. complete as per direction of Engineer in charge. (Geotextile delivered at site should be certified by ISO and clearly labelled with brand name and grade printed at regular intervals across the body of the fabric).	sqm
40-600-10	Mass $\Rightarrow 200$ gm/m ² , thickness(Under 2 kpa pressure) $\Rightarrow 1.50$ mm, EoS ≤ 0.12 mm, strip tensile strength $\Rightarrow 11$ kn/m, grab strength $\Rightarrow 600$ N, CBR puncture resistance $\Rightarrow 1600$ N.	sqm
40-600-20	Mass $\Rightarrow 300$ gm/m ² , thickness(Under 2 kpa pressure) $\Rightarrow 2.00$ mm, EoS ≤ 0.11 mm, strip tensile strength $\Rightarrow 15$ kn/m, grab strength $\Rightarrow 850$ N, CBR puncture resistance $\Rightarrow 2200$ N.	sqm
40-600-30	Mass $\Rightarrow 350$ gm/m ² , thickness(Under 2 kpa pressure) $\Rightarrow 2.50$ mm, EoS ≤ 0.09 mm, strip tensile strength $\Rightarrow 20$ kn/m, grab strength $\Rightarrow 1200$ N, CBR puncture resistance $\Rightarrow 3200$ N.	sqm
40-600-40	Mass $\Rightarrow 400$ gm/m ² , thickness(Under 2 kpa pressure) $\Rightarrow 3.00$ mm, EoS ≤ 0.08 mm, strip tensile strength $\Rightarrow 23$ kn/m, grab strength $\Rightarrow 1500$ N, CBR puncture resistance $\Rightarrow 3800$ N.	sqm
40-600-50	Mass ≥ 550 gm/m ² ; thickness(Under 2 kpa pressure) ≥ 4.0 mm, EoS ≤ 0.06 mm,strip tensile strength ≥ 30 KN/m; grab strength ≥ 1850 N; CBR puncture resistance ≥ 5100 N.	sqm

ITEM DEFINITION REPORT

ItemCode	Item Description	Unit Meas.
40-605	Supply & placing of woven type Natural Additive Treated Jute Geo-textile (JGT) for effective erosion protection in hydraulic structures/river training works including local handling, placing in position including protecting the Jute Geo-textile (JGT) material from any damages including supply of all materials, labours, equipments etc. following the technical specification and installation method complete as per direction of Engineer in charge.	sqm
40-605-10	Mass ≥ 627 gm/m ² , thickness(Under 2 kpa pressure) ≥ 2.00 mm	sqm
40-610	Supplying and laying dry 1st class or pick jhama chips as filter in two layers (top and bottom) as per specific size, range and gradation, including breaking chips, grading, preparation of surface, compacting each layer etc. complete with supply of all materials and as per direction of Engineer in charge:	cum
40-610-10	Well graded between 50mm to 20mm size.	cum
40-610-20	Well graded between 40mm to 20mm size.	cum
40-610-30	Well graded between 20mm to 5mm size. (Combination of sub-item 10 & 30 or 20 & 30 shall be used)	cum
40-620	Supplying and laying shingles and peagravels as filter in two layers (top and bottom) as per specific size ranges and gradation including grading, preparation of surface, compacting each layer etc. complete with supply of all materials and as per direction of Engineer in charge:	cum
40-620-10	Well graded between 50mm to 20mm size.	cum
40-620-20	Well graded between 40mm to 20mm size.	cum
40-620-30	Well graded between 20mm to 5mm size. (combination of sub-item 10 and 30 or 20 and 30 shall be used).	cum
40-640	Supplying and laying stone chips as filter in two layers (Top and bottom) as per specific size ranges and gradation including preparation of surface, grading, compacting each layer etc. complete with supply of all materials and as per direction of Engineer in charge.	cum
40-640-10	Well graded between 50mm to 20mm size.	cum
40-640-20	Well graded between 40mm to 20mm size.	cum
40-640-30	Well graded between 20mm to 5mm size. (Combination of sub-items 10 & 30 or 20 & 30 shall be used).	cum
40-650	Supplying and laying sand as filter layers as per specific size ranges and gradation including preparation of surface, compacting in layer etc. complete with supply of all materials and as per direction of Engineer in charge.	cum
40-650-10	FM : 2.0 to 2.5	cum
40-650-20	FM : 1.5 to 2.0	cum
40-650-30	FM : 1.0 to 1.5	cum

ITEM DEFINITION REPORT

ItemCode	Item Description	Unit Meas.
40-700	Brick mattressing work, 150 mm thick, with 1st. class bricks, encased in double layers of 12 SWG galvanised wire netting, 100 mm hexagonal mesh, including fixing, spreading and tying both upper and lower layers with 12 SWG galvanised wire at 60cm c/c including anchoring with 1.5m long 75mm to 100mm dia wooden/bamboo post at 3.0m c/c both ways (at least 1.2m of the post shall be driven under ground and 0.3m shall be above ground level to facilitate tying), box cutting to required depth, fine dressing of base and supplying of all materials etc. complete and as per direction of Engineer in charge:	sqm
40-730	Labour charge for brick mattressing work, 150 mm thick, with 1st class bricks, encased in double layers of 12 SWG galvanised wire netting, 100mm hexagonal mesh, including fixing, spreading and tying both upper and lower layers, with 12 SWG galvanised wire at 60cm c/c, including anchoring with 1.5m long 75mm to 100mm dia wooden/bamboo posts at 3.0m c/c both ways (at least 1.2m of the post shall be driven under ground and 0.3m shall be above ground to facilitate tying), box cutting to required depth and fine dressing of base, excluding the cost of bricks, wire net and G.I. wire, but including the cost of bamboo/wooden posts etc. complete and as per direction of Engineer in charge:	sqm
40-750	Labour charge for brick mattressing with 1st class bricks, 75mm thick, covered with single layer of 12 SWG galvanised wire netting, 100mm hexagonal mesh, including fixing, spreading and tying with 12 SWG galvanised wire and anchoring with 1.5m long 75mm to 100mm dia bamboo at 3.0m c/c both ways, box cutting to required depth, fine dressing of base, excluding the cost of bricks, wire net and G.I. wire, but including the cost of bamboo pegs etc. complete and as per direction of Engineer in charge.	sqm
40-760	Manufacturing and supplying 100mm size hexagonal mesh wire netting crates of 12 SWG galvanised wire, filling the same with boulders/bricks/brick bats (not smaller than half brick) and stitching with 12 SWG galvanised wire, tying the same and laying in position under water in bed or slope of canal/river, with supply of all materials etc. complete and as per direction of Engineer in charge:	each
40-760-10	0.90mx0.60mx0.45m, with first class bricks/brick bats (minimum 1/2 brick).	each
40-760-20	0.90mx0.60mx0.45m, with boulders (minimum size 120mm).	each
40-760-30	0.60mx0.60mx0.45m, filled with first class bricks/brick bats (minimum 1/2 brick).	each
40-760-40	0.60mx0.60mx0.45m, filled with boulders (minimum size 120mm).	each
40-760-50	0.50mx0.50mx0.45m, filled with first class bricks/brick bats (minimum 1/2 brick).	each
40-760-60	0.50mx0.50mx0.45m, filled with boulders (minimum size 120mm).	each
40-770	Labour charge for untying and removing the wire nets and picking the bricks and stacking properly the same as per direction of Engineer in charge:	sqm

ITEM DEFINITION REPORT

ItemCode	Item Description	Unit Meas.
40-770-10	75mm thick brick mattressing.	sqm
40-770-20	150mm thick brick mattressing.	sqm
40-780	Supplying and making 1.80mx1.80mx1.80m bamboo, porcupines including 0.60mx0.60mx0.60m chamber by 75mm to 100mm dia barak bamboo with minimum 200mm long nails and string, filling the chamber with 1st. class brick bates(not smaller than 1/2 brick/ boulders (not less than 150mm), as per approved design and placing/ dumping the same in position under water in slope and in bed of the river etc. complete and as per direction of Engineer in charge.	each
40-780-10	Filled with bricks/brickbats.	each
40-780-20	Filled with boulders.	each
40-800	Construction of double row bamboo spur, with full length barrack bamboo, 60mm to 75mm dia and 3.0m to 4.5m long, 0.30m c/c, 1.5m apart and single row runner with half split bamboo on both sides, of each row, fixing with country nails, and 1.5m apart, double layers cross tie at 3.0m interval and 1.5m apart, including 2.4m to 3.0m driving of bamboo pins by monkey hammer, necessary staging etc. complete with supply of all materials and as per drawing and direction of Engineer in charge.	m
40-810	Construction of double row bamboo spur, with full length barrack bamboo of average 60mm to 75mm dia and 4.5m to 6.0m long, at 0.30m c/c, two rows at 1.5m apart and stays with bamboo at 3.0m apart on D/S side of the spur and single row runner with half split bamboo on both sides of each row and double layers cross tie at 3.0m interval, including 2.4m to 3.0m driving of bamboo pins by monkey hammer, necessary staging etc. complete with supply of all materials including local carriage within 150m and as per drawing and direction of Engineer in charge.	m
40-820	Construction of double row bamboo spur, with full length barrack bamboo of average 75mm to 100mm dia, 7.5m to 11.0m long, at 0.3m c/c, two rows at 1.5m apart and stays with bamboo at 3.0m apart on the D/S side of the spur and double row runner with half split bamboo on both sides of each row, double layer cross tie at 3.0m interval, including 2.4m to 3.0m driving of bamboo pins by monkey hammer, necessary staging etc. complete with supply of all materials including local carriage within 150m and as per drawing and direction of Engineer in charge.	m
40-850	Construction of single row bamboo spur, with full length barrack bamboo of average 60mm to 75mm dia and 6.0m to 7.5m long, at 0.3m c/c and stays with bamboo at 3 m apart on the D/S side of the spur, double row runner with half split bamboo on both sides and also with double layer cross tie at 3.0m interval, including 2.4m to 3.0m driving of bamboo pins by monkey hammer, necessary staging etc. complete with supply of all materials including local carriage within 150m and as per drawing and direction of Engineer in charge.	m

ITEM DEFINITION REPORT

ItemCode	Item Description	Unit Meas.
40-880	Supplying of brush wood compacted in bundle not more than 75cm. dia and 180cm. in length tied securely with coir string and dumping the same in position etc. complete with supply of all materials and as per direction of Engineer in charge.	cum
40-900	Earth work in cutting and filling of eroded bank of river, channel etc. to design slope, including levelling, dressing and compacting the earth in 150mm layers and preparation of the base for bank protection work as per direction of Engineer in charge.	cum

ITEM DEFINITION REPORT

ItemCode	Item Description	Unit Meas.
44 . Piling and Caisson Sinking		
44-100	Driving precast RCC pile upto 15.0 m length including layout, providing center line and Bench Mark pillars, carriage of piles from yard to driving point and driving through hard strata, if any, including the cost of installation, demobilization and carriage of all equipments, auxillary items, labours, materials etc. complete, as per direction of Engineer in charge.	m
44-100-10	Size 200mm x 200mm	m
44-100-20	Size 250mm x 250mm	m
44-100-30	Size 300mm x 300mm	m
44-100-40	Size 350mm x 350mm	m
44-100-50	Size 400mm x 400mm	m
44-110	Manufacturing, supplying and fitting fixing M.S.Shoe at RCC pile tip with tip area 20mmx20mm, butt area 135mmx135mm and height 200mm, fabricated with 6mm thick 4 nos M.S. plate (20mmx135mmx200mm) at sides and one plate (20mmx20mm) at tip, having 6mm thick continuous fillet weld at all joints and 16mm dia 500mm long anchor bar welded to the tip plate at one end and hooked at the other end etc. complete including cost of all materials and as per direction of Engineer in charge.	each
44-115	Construction of R.C.C. cast in situ bored piles in 1:1.5:3 upto required depth in all types of soils including drilling and driving & extracting temporary steel casing upto required depth where necessary with bentonite circulation, casting concrete with cement, sand (FM \geq 2.50) and 20 mm down graded stone chips in leanest mix. 1:1.5:3 having minimum 28 day cylinder strength of 22.0 N/mm ² including the cost of all materials, labour, equipments and all incidental charges excluding the cost of M.S. work for reinforcement etc. complete in all respect (measurement will be given from the bottom of the pile cap) as per design, drawing, specification and direction of Engineer in charge.	m
44-115-10	400mm dia.	m
44-115-20	500mm dia.	m
44-115-30	600mm dia.	m
44-115-40	700mm dia.	m
44-115-50	800mm dia.	m
44-115-60	900mm dia.	m

ITEM DEFINITION REPORT

ItemCode	Item Description	Unit Meas.
44-120	Construction of R.C.C. cast in situ bored piles in 1:1.5:3 upto required depth in all types of soils including drilling and driving & extracting temporary steel casing upto required depth where necessary with bentonite circulation, casting concrete with cement, sand (FM \geq 2.50) and 20mm down graded shingles in leanest mix. 1:1.5:3 having minimum 28 day cylinder strength of 22.0 N/mm ² including the cost of all materials, labour, equipments and all incidental charges excluding the cost of M.S. work for reinforcement etc. complete in all respect (measurement will be given from the bottom of the pile cap) as per design, drawing, specification and direction of Engineer in charge.	m
44-120-10	400mm dia.	m
44-120-20	500mm dia.	m
44-120-30	600mm dia.	m
44-120-40	700mm dia.	m
44-120-50	800mm dia.	m
44-120-60	900mm dia.	m
44-130	Supplying and installation of best quality M.S. pipe of 6mm wall thickness of different diameter (Inner) to work site for bored cast in situ pile as permnent casing including loading, unloading, carrying and all sorts of handling, taxes, incidental charges, fitting and fixing the same in position by making all arrangements etc. complete, as per design, specification and direction of Engineer in charge.	m
44-130-10	400mm dia.	m
44-130-20	500mm dia.	m
44-130-30	600mm dia.	m
44-130-40	700mm dia.	m
44-130-50	800mm dia.	m
44-130-60	900mm dia.	m
44-130-70	250 mm dia.	m
44-130-80	200 mm dia.	m
44-140	Labour for breaking of head of cast in situ bored pile/precast pile upto required length by any means and removing the dismantled materials such as concrete to a safe distance including scrapping and removing concrete from steel/M.S. rods, all sorts of handling, stacking the same properly after clearing, levelling and dressing the site and clearing the river bed etc. complete as per direction of Engineer in charge.	cum

ITEM DEFINITION REPORT

ItemCode	Item Description	Unit Meas.
44-150	Providing and making point welding at contact point of the spiral binders at 0.5m intervals with the main reinforcements by electric arc welding and the rest to be binding with G.I. wire for construction of cast in situ bored pile carefully with highly oxidised electrodes making the point including the cost of all materials, labour, tools, plants and equipments, cost of power etc. complete in all respect as per direction of Engineer in charge.	point
44-160	Providing and making joint of welding of minimum 300mm length at the lapping portion of main reinforcements by electric arc welding for construction of cast in situ bored pile carefully with highly oxidised electrodes making the joint prominent, including the of cost of all materials, labour, tools, plants and equipments, cost of power etc. complete in all respects as per direction of Engineer in charge.	m
44-180	Carrying out pile load test with at least 2 times of designed load for precast or cast in situ piles at sites, according to the ASTM standard specification including the cost of installation of all kinds of equipments, materials, labour, technical manpower etc. for conducting load tests and removing the installations and applied load after test etc. complete as per direction of Engineer in charge.	each
44-180-10	Design load upto 25.00 tonne.	each
44-180-20	Design load upto 50.00 tonne.	each
44-180-30	Design load upto 75.00 tonne.	each
44-200	Construction of pile yard for casting RCC pile with 50mm thick cement concrete (1:3:6) with cement, sand (FM \geq 1.5) and 20mm down graded picked jhama or 1st class brick chips including breaking, screening, grading and washing chips, mixing, laying and compacting to levels, over a brick flat soling with 1st class bricks including preparation of base, sand filling to make a level base, ramming and sand blinding with sand of FM \geq 0.8 etc. complete with neat cement finish over the concrete surface including the cost for supply of all materials and as per direction of Engineer in charge.	sqm
44-220	Supplying and laying single layer polythene sheet in floor below cement concrete, RCC slab, on walls etc. complete in all respect as per direction of Engineer in charge.	sqm
44-220-10	Weighing minimum 1.0 kg per 6.50 sqm.	sqm
44-220-20	Weighing minimum 1.0 kg per 16.0 sqm.	sqm
44-240	Supplying at site U-shape hot rolled steel sheet pile of different section of Phosphorus=0.04%(Maximum), Sulphur = 0.04% (Maximum), Tensile strength= \geq 490 N/mm ² , Yield strength \geq 296 N/mm ² , Elongation =15% (Minimum) including all taxes, freights, incidental charges etc. complete as per direction of the Engineer -in- charge.	m.ton
44-240-10	U-shape, hot- rolled steel sheet pile width= 400mm to 600mm: height= \geq 100mm, Thickness \geq 10.5mm. (\pm 0.50mm)	m.ton

ITEM DEFINITION REPORT

ItemCode	Item Description	Unit Meas.
44-240-20	U-shape, hot- rolled steel sheet pile width= 400mm to 600mm: height=> 130mm, Thickness>=13.0mm. (±0.50mm)	m.ton
44-240-30	U-shape, hot- rolled steel sheet pile width= 400mm to 600mm: height=> 170mm, Thickness>=15.5mm. (±0.50mm)	m.ton
44-270	Driving steel sheet piles of various sections and weights of any type of soil, by monkey hammer including handling and placing in position, staging and supplying of all equipments like monkey hammer, pully, rope, bamboo, bullah etc. including correcting leaning beyond tolerance & other defects and any other incidental cost etc. complete (measurement will be taken on projected width x height) as per direction of Engineer in charge.	sqm
44-270-10	Flat type : Upto 4.50 m depth.	sqm
44-270-20	U-type or any other type : Upto 4.50 m depth.	sqm
44-290	Driving steel sheet piles of various sections and weights of any type of soil, by mechanical device including handling and placing in position including supply of all materials and equipments related with driving of sheet piles including correcting leaning beyond tolerance and other defects etc. complete (measurement will be taken on projected width x height) as per direction of Engineer in charge.	sqm
44-290-10	Flat type : Upto 6.50 m depth.	sqm
44-290-20	Flat type : Upto 12.50 m depth.	sqm
44-290-30	U-type or any other type : Upto 6.50 m depth.	sqm
44-290-40	U-type or any other type : Upto 12.50 m depth.	sqm
44-300	Lifting steel sheet piles of any section and weights from any type of soil by mechanical device including handling and placing in stacks etc. complete (measurement will be taken on projected width x height)including supply of all equipments etc. complete as per direction of Engineer in charge.	sqm
44-310	Supplying and placing 20mm thick hessian cloth impregnated with bitumen in expansion joints or on top of sheet piles as per specification and direction of Engineer in charge.	sqm
44-320	Cutting of steel sheet piles to design length and shape as per requirement in design and drawing and as per direction of Engineer in charge.	m
44-320-10	Upto 10mm thick.	m
44-320-20	Above 10mm thick.	m
44-330	Jointing steel sheet piles Of different thickness by welding to increase the length of pile as per requirement including necessary modification of the ends to receive the weld, supply of welding materials, equipments and other accessories as per specification and direction of Engineer in charge.	m

ITEM DEFINITION REPORT

ItemCode	Item Description	Unit Meas.
44-340	Fabrication and construction of corner Joints in steel sheet piles including cutting, welding, shaping as per design and specification and as per requirement including supply of necessary welding materials, equipments and other accessories as per specification and direction of Engineer in charge.	m
44-360	Sinking open caisson in all kinds of soils by using mechanical or manually operated grabs including use of bentonite or any other appropriate slurry for facilitating driving, additional weight where necessary etc. complete including supply of all equipments, manpower and other allied materials etc. complete (measurement will be given for outside face of caisson sunk) as per direction of Engineer in charge.	sqm
44-360-10	0.00 m to 3.00 m.	sqm
44-360-20	3.00 m to 6.00 m.	sqm
44-360-30	6.00 m to 9.00 m.	sqm
44-360-40	Above 9.00 m.	sqm
44-370	Manufacturing and supplying 30mm thick pre-cast ferro-cement sheet pile in construction of drain/ sluice/ culvert/ outlet and any other works in leanest mix 1:2 with sand of FM \geq 2.0 to attain a minimum 28 day cylinder strength of 20.00 N/mm ² including screening, grading and washing aggregates with clear water, mixing, laying in forms, consolidating, curing, testing, placing wire-mesh in position, welding, including making grooves and keys as per approved design and drawing including tools, plants, preparation of platform, shuttering (timber shutter with sheet lining and polythene sheet) and stacking in measurable stacks including cost of all materials and labour (excluding the cost of M.S work for reinforcement) etc. complete as per direction of Engineer in charge.	sqm
44-380	Driving pre-cast ferro-cement sheet pile upto 2.0 m depth including layout, providing centreline and bench mark pillars, carriage of piles from yard to driving point, placing the same in row and position, staging, plumbing, providing horizontal runners, water jetting where necessary including supply of all equipments like timber dolly, pulley, rope, bamboo, bullah, hammer etc. complete (measurement will be taken on projected width x height) as per direction of Engineer in charge.	sqm
44-400	Execution of sand pile through displacement method by using tripod rig, mechanical winch, special type drop hammer (weighing minimum 1.00 ton) and casing pipe of inner dia 250mm to 300mm upto a maximum depth of 6.5m, compacting the sand with desired sand force volume and FM value of sand upto desired relative density (60% to 65%), to attain the desired SPT value between sand piles etc. complete including the cost of compacted sand as per design, specification and direction of Engineer in charge.	m
44-400-05	Sand force Vol. 0.15 cum/m, FM \geq 1.5	m
44-400-10	Sand force Vol. 0.15 cum/m, FM \geq 2.0	m

ITEM DEFINITION REPORT

ItemCode	Item Description	Unit Meas.
44-400-15	Sand force Vol. 0.15 cum/m, FM>=2.5	m
44-400-20	Sand force Vol. 0.20 cum/m, FM>=1.5	m
44-400-25	Sand force Vol. 0.20 cum/m, FM>=2.0	m
44-400-30	Sand force Vol. 0.20 cum/m, FM>=2.5.	m
44-400-35	Sand force Vol. 0.25 cum/m, FM>=1.5	m
44-400-40	Sand force Vol. 0.25 cum/m, FM>=2.0	m
44-400-45	Sand force Vol. 0.25 cum/m, FM>=2.5	m
44-400-50	Sand force Vol. 0.30 cum/m, FM>=1.5	m
44-400-55	Sand force Vol. 0.30 cum/m, FM>=2.0	m
44-400-60	Sand force Vol. 0.30 cum/m, FM>=2.5	m
44-400-65	Sand force Vol. 0.35 cum/m, FM>=1.5	m
44-400-70	Sand force Vol. 0.35 cum/m, FM>=2.0	m
44-400-75	Sand force Vol. 0.35 cum/m, FM>=2.5	m

ITEM DEFINITION REPORT

ItemCode	Item Description	Unit Meas.
48 . Turfing and Tree Planting		
48-100	Fine dressing and close turfing of the slopes and the crest of embankment with 75mm thick, good quality durba or charkanta sods of size 200mm x 200mm, with all leads and lifts, including ramming, watering until the turf grows properly, maintaining etc. complete (measurement will be given on well grown grass only). as per direction of Engineer in charge.	sqm
48-110	Plantation of vetiver Grass (Binnah Ghass) tiller @ 0.20m c/c interval in 1.00m(one meter) horizontal and vertical grid with all leads & lifts in the slope of the embankment for protection of rain-cuts,erosion control,wave action etc. including supplying of vetiver grass tiller produced in the nursery, ramming the loose soil properly during plantation, nursing and maintenance of vetiver grass, dug bailing and watering until the vetiver grass grown properly (Measurement will be given on well grown vetiver grass only) as per direction of the Engineer-in-charge.	sqm
48-130	Biological protection of bare earth surface by Dholkalmi with minimum 50cm long sapling, planting @ not more than 30 cm apart including supplying, sizing, taping and nursing etc. complete as per direction of the Engineer in charge.	m
48-210	Plantation of coconut plant including cutting earth and supplying at site 75cm to 90cm long plant including putting manure and salt by digging 60cm dia hole to a depth of average 45cm, supplying 10.0 kg of manure & 1.0 kg. salt and keeping it wet for one month before plantation including guarding and watering the plant for 6 months as per direction of Engineer in Charge.	each
48-220	Plantation of all kinds of timber plants and fruit plants such as Mehegany, Teak, Sal, Chamble, Mango, Jack, Lichi, Kul etc including cutting earth and supplying at site average 1.0m height plant, including putting manure by digging 45cm dia hole, to a depth of average 30cm, supplying and mixing 7.56 kg of manure, tying the plant with 1.50m split bamboo post and keeping it wet for one month before plantation including guarding the plant for 6 months as per direction of Engineer in Charge.	each
48-230	Supplying at site materials for plantation of trees, as per direction of Engineer in charge.	kg
48-230-10	Cow dung	kg
48-230-20	Salt	kg
48-230-30	Urea	kg
48-230-40	Daow	each
48-230-50	Kodal (standard size)	each
48-230-60	Tukri (standard size)	each
48-230-70	Nirani (standard size)	each
48-230-80	Bucket (25 cm to 31 cm)	each

ITEM DEFINITION REPORT

ItemCode	Item Description	Unit Meas.
48-230-90	Water sprayer	each
48-300	Supplying of bamboo jafry gabion of 1.40m height and 60cm average dia, including fixing by barrack bamboo post of 60mm to 70mm dia including fitting and fixing etc. complete.	each
48-310	125mm thick jally brick work of 2nd class bricks, with sand and cement mortar (1:6), 90cm dia inside and 140cm height above the ground level, 30cm solid brick work below ground level, including finishing 15cm top bend with 12mm thick cement plaster (1:6) and cutting foundation etc. complete as per direction,including white washing outside surface of gabion with supply of all materials and as per direction of Engineer in charge.	each

ITEM DEFINITION REPORT

ItemCode	Item Description	Unit Meas.
52 . Dismantling and Repair Work		
52-100	Dismantling of brick soling work including cleaning and stacking bricks within 60m as per direction of Engineer in charge.	sqm
52-100-10	75mm flat soling.	sqm
52-100-20	125mm HBB soling.	sqm
52-100-30	150mm flat soling.	sqm
52-100-40	200mm (flat & HBB) soling.	sqm
52-110	Dismantling of construction works, including removing debris within 60m as per direction of Engineer in charge.	cum
52-110-10	cement or lime concrete work	cum
52-110-20	reinforced cement concrete work	cum
52-110-30	brick masonry in cement	cum
52-120	Dismantling of artificial stone flooring upto a minimum depth of 25mm carefully, including removing debris at specified place as per direction of Engineer in charge.	sqm
52-130	Dismantling of the C.I. sheet walling/roofing and stacking the materials at site as per direction of Engineer in charge.	sqm
52-130-10	from roofing	sqm
52-130-20	from walling	sqm
52-180	Dismantling of Cement Concrete/brick lining upto 100 mm thick of irrigation canal bed and slope carefully including removing debris at specified place as per direction of Engineer in charge.	sqm
52-180-10	Cement Concrete lining.	sqm
52-180-20	Brick lining.	sqm
52-210	Dismantling of brick on end edging of 1st class bricks and picked jhama bricks and stacking the same within 60m in measurable stacks as per direction of Engineer in charge.	sqm
52-210-10	75mm across the road	sqm
52-210-20	125mm across the road	sqm
52-220	Dismantling compacted khoa consolidation upto 200mm thick and stacking the materials within 60m in measurable stacks as per direction of Engineer in charge.	cum
52-230	Dismantling of compacted bituminous carpeting upto 75mm thick and removing the debris within 60m as per direction of Engineer in charge.	sqm

ITEM DEFINITION REPORT

ItemCode	Item Description	Unit Meas.
52-250	Stripping of old plaster, clearing the surface, racking out joints of brick work and watering etc. complete as per direction of Engineer in charge.	sqm
52-290	Repairing of cracks with sand and cement in proportion 1:4, including watering, curing etc. complete including supply of all materials as per direction of Engineer in charge.	m
52-310	Repairing of cracks with jhama chips, sand and cement (1:2:4), including opening out cracks 125mm wide and 75mm deep and watering, finishing etc. complete including supply of all materials as per direction of Engineer in charge.	m
52-320	Repairing of cracks 25mmx12mm on floor with cement mortar, in proportion 1:2 including supply of all materials as per direction of Engineer in charge.	m
52-340	Repairing of roof cracks with lime concrete (2:2:7), including opening out cracks in V-shaped notch (100mm wide and 50mm deep), cleaning, compacting, curing, etc. complete including supply of all materials as per direction of Engineer in charge.	m
52-350	Repairing of roof cracks with coal tar and pitch (3 coal tar and 1 pitch), in two layers reinforced with jute cutting, including cutting grooves 75mmx50mm size, removing debris and sand blinding on top etc. complete (F.M. of sand >=1.50) including supply of all materials as per direction of Engineer in charge.	m
52-360	Renewing old cast in situ mosaic by pumic stone for removing top skin layer including the mosses, undesired spots and mending the damages where necessary and polishing the surface including the cost of all materials, labours, equipments etc. complete as per direction of Engineer in charge.	sqm
52-380	Stopping leakage in C.I. sheet with putty and cotton etc. complete including supply of all materials as per direction of Engineer in charge.	no

ITEM DEFINITION REPORT

ItemCode	Item Description	Unit Meas.
56 . Road Construction		
56-100	Earth work in box cutting up to 1.00 m depth, in all kinds of soil with all leads, removing the spoils to a safe distance, including levelling and dressing, maintaining required cambering etc. complete, as per direction of Engineer in charge.	cum
56-105	Construction of road sub-grade of sand (FM \geq 0.5) in maximum 150mm thick layer including dressing, levelling, ramming, watering, cambering and compacting to attain minimum CBR-5% by manual labour using mallet/ vibro compactor and compacted to achieve 95% of maximum dry density including cost of all materials etc. complete as per design, drawing and direction of Engineer in charge (payment shall be made on compacted volume).	
56-105-10	Construction of Subgrade: 300 mm depth	sqm
56-105-20	Construction of Subgrade: 450 mm depth	sqm
56-110	Construction of improved road sub-grade of sand (FM \geq 0.8) in maximum 150mm thick layer including dressing, levelling, ramming, watering, cambering and compacting to attain minimum CBR-8% by manual labour using mallet/ vibro compactor and compacted to 95% of maximum dry density including cost of all materials etc. complete as per design, drawing and direction of Engineer in charge (payment shall be made on compacted volume).	cum
56-120	Brick flat soling with 1st class bricks, including preparation of bed, sand blinding (FM \geq 0.5), levelling, dressing including supply of all materials etc. complete as per direction of Engineer in charge.	sqm
56-120-10	Single layer.	sqm
56-120-20	Double layer.	sqm
56-130	Brick on edge soling in Herring Bone Bond (HBB) with 1st class bricks, including preparation of bed, sand blinding (FM \geq 0.5), levelling, dressing including supply of all materials etc. complete as per direction of Engineer in charge.	sqm
56-140	Brick on end edging (single layer) across the road, with 1st class bricks, including cutting trenches true to level and grade, sand filling (FM \geq 0.5), 40mm thick, sand blinding, levelling, dressing, ramming sides properly including supply of all materials etc. complete as per direction of Engineer in charge.	m
56-140-10	75 mm thick.	m
56-140-20	125 mm thick.	m

ITEM DEFINITION REPORT

ItemCode	Item Description	Unit Meas.
56-150	Construction of road sub-base with graded materials of crushed well burnt picked jhama or first class brick chips (50mm down graded) mixed with sand (FM \geq 1.0) in proportion 2:1 (chips:sand), and spreading uniformly in maximum 150mm thick layers (Loose) to proper camber, grade and super elevation where necessary including dressing, levelling, ramming, watering and compacting to attain minimum CBR-25% by 8.0 to 10.0 m.ton power driven road roller compacted to 98% of maximum dry density, Aggregate Crushing Value (ACV) should not be greater than 38%, Ten Percent Fine Value should not be less than 75 KN including including cost of all materials etc. complete as per design, drawing and direction of Engineer in charge (payment shall be made on compacted thickness).	cum
56-200	Construction of road base type-1 with graded materials of Crushed boulder/gravel aggregate (40mm down graded) mixed with sand (FM \geq 1.0) in proportion 2:1 (stone chips : sand), and spreading uniformly in maximum 150mm thick layers (Loose) to proper camber, grade and super elevation where necessary including dressing, levelling, ramming, watering and compacting to attain minimum CBR-80% by 8.0 to 10.0 m.ton power driven road roller and compacted to 98% of maximum dry density, Aggregate Crushing Value (ACV) <30%, Los Angeles Abrasion Value (LAA) < 35% including cost of all materials etc. complete as per design, drawing and direction of Engineer in charge (payment shall be made on compacted thickness).	cum
56-210	Construction of road base type-2 with graded materials of crushed well burnt picked jhama or first class brick chips (40mm down graded) mixed with sand (FM \geq 1.0) in proportion 2:1 (brick chips : sand), and spreading uniformly in maximum 150mm thick layers (Loose) to proper camber, grade and super elevation where necessary including dressing, levelling, ramming, watering and compacting to attain minimum CBR-50% by 8.0 to 10.0 m.ton power driven road roller and compacted to 98% of maximum dry density, Aggregate Crushing Value (ACV) <35%, Los Angeles Abrasion Value (LAA) < 40% including cost of all materials etc. complete as per design, drawing and direction of Engineer in charge (payment shall be made on compacted thickness).	cum
56-230	Compacted water bound macadam base course with 1st. class or picked jhama brick chips in two layers and in two operations, 1st. layer with chips between 40mm to 25mm down graded sizes and 2nd. layer with chips between 25mm to 20mm down graded sizes, thickness of each layer (loose) shall not exceed 120mm, including breaking, screening, grading chips, spreading, packing, ramming, compacting with 8 to 10 m.tonne power driven road roller in each layer in dry and wet condition, watering properly to attain minimum CBR-80% to level, grade, camber superelevation including cost of all materials and equipments etc. complete as per design, drawing and direction of Engineer in charge (payment shall be made on compacted volume, reduction of loose height by 30% to 35% may be allowed on maximum possible compaction).	cum

ITEM DEFINITION REPORT

ItemCode	Item Description	Unit Meas.
56-240	50mm thick premixed bitumenous carpetting with specified well graded stone chips (25mm to 4.0 mm) @ 0.06 cum. of stone chips mixed with 72 kg. of bitumen (heated between 170 deg. centigrade & 190 deg. centigrade) per cum. of stone chips, while still hot the resulting mixture is to be spreaded uniformly over 1.0 sqm. prepared surface in proper camber, grade and superelevation and rolling hard to full compaction with 8 to 12 M. tons power driven road roller and spreading 0.012 cum. sand (FM \geq 0.80) per sqm. including supply of all materials and equipments etc. complete as per direction of Engineer in charge.	sqm
56-250	40mm thick premixed bitumenous carpetting with specified well graded stone chips (20mm to 4.0 mm) @ 0.048 cum. of stone chips mixed with 80 kg. of bitumen (heated between 170 deg. centigrade & 190 deg. centigrade) per cum. of stone chips, while still hot the resulting mixture is to be spreaded uniformly over 1.0 sqm. prepared surface in proper camber, grade and superelevation and rolling hard to full compaction with 8 to 12 M. tons power driven road roller and spreading 0.012 cum. sand (FM \geq 0.80) per sqm. including supply of all materials and equipments etc. complete as per direction of Engineer in charge.	sqm
56-260	30mm thick premixed bitumenous carpetting with specified well graded stone chips (20mm to 4.0 mm) @ 0.038 cum. of stone chips mixed with 80 kg. of bitumen (heated between 170 deg. centigrade & 190 deg. centigrade) per cum. of stone chips, while still hot the resulting mixture is to be spreaded uniformly over 1.0 sqm. prepared surface in proper camber, grade and superelevation and rolling hard to full compaction with 8 to 12 M. tons power driven road roller and spreading 0.012 cum. sand (FM \geq 0.80) per sqm. including supply of all materials and equipments etc. complete as per direction of Engineer in charge.	sqm
56-270	Minimum 75mm thick compacted semi grouting with stone metal and hot bitumen laying and spreading stone metal 100mm thick (loose) in two layers, 1st. layer of 60mm thick (loose) with 40mm to 25mm size and 2nd. layer of 40mm thick (loose) mixing with 80% of 25mm to 20mm size and 20% of 20mm to 10mm size stone chips to proper camber level, grade and superelevation and spreading hot bitumen @ 1.50kg. per sqm. on the 1st. layer and 2.00kg. hot bitumen per sqm. on the 2nd. layer, rolling hard to full compaction with 8 to 12 M. tons power driven road roller including heating bitumen to 170 deg. C. to 190 deg. C. temp. and spreading stone chips 0.09 (0.06+0.024+0.006) cum. per sqm. road surface obtained from screening of stone metal after breaking of boulders to make it dense, voidless and water tight etc. complete including supply of all materials and equipments and as per direction of Engineer in charge.	sqm

ITEM DEFINITION REPORT

ItemCode	Item Description	Unit Meas.
56-280	Minimum 75mm thick compacted semi grouting with brick metal 25mm down graded khoa and hot bitumen laying and spreading metal @ 110mm thick (loose) in two layers of 70mm and 40mm to proper camber level, grade and superelevation and applying hot bitumen @ 1.70kg. per sqm, uniformly in the 1st. layer and 2.50kg. hot bitumen per sqm. on the 2nd. layer over a tack coat of 1.25kg. per sqm. bitumen, after cleaning the road surface with brush broom and gunny bags and removing the debries to safe distance (the surface should be quite dry) and rolling hard to full compaction with 8 to 10 M. tons power driven road roller including heating bitumen to 170 deg. C. to 190 deg. C. temp. including supply of all materials and equipments etc. complete as per direction of Engineer in charge.	sqm
56-290	Average 50mm thick compacted semi grouting with brick metal 25mm down graded khoa and hot bitumen in one layer to develop the damaged, depressed and undulated surface of the road, laying, spreading metal @ 75mm thick (loose) etc.to proper camber level, grade and superelevation and spreading hot bitumen @ 2.50kg. per sqm. rolling hard to full compaction with 8 to 10 M. tons power driven road roller including heating bitumen to 170 deg.C.to 190 deg.C. temp. including supply of all materials and equipments etc. complete and as per direction of Engineer in charge.	sqm
56-300	Providing tack coat @ 0.75kg. of bitumen per sqm. including heating bitumen to 170 deg. C. to 190 deg. C. temperature, spreading and supply of all materials etc. complete and as per direction of Engineer in charge.	sqm
56-310	Pre-mixed bitumenous seal coat minimum 9mm thick compacted with 0.015 cum. of peagravels mixed with 80 kg. of bitumen per cum. of pregravels and laid over 1.0 sqm. of road surface including spreading with proper camber and blinding with dry sand @ 0.01 cum. (FM \geq 0.80) per sqm. rolling with 8 to 10 M. tons power driven road roller including supply of all materials and equipments etc. complete as per direction of Engineer in charge.	sqm
56-320	Pre-mixed bitumenous seal coat with 0.015 cum. of coarse sand (FM=2.0 to 2.8) mixed with 96kg. of bitumen per cum. of sand and laid over 1.0 sqm. of road surface including spreading with proper camber and blinding with dry sand @ 0.01 cum. (FM \geq 0.80) per sqm. rolling with 8 to 10 M. tons power driven road roller including supply of all materials and equipments etc. complete as per direction of Engineer in charge.	sqm
56-330	Pre-mixed bitumenous seal coat with 0.012 cum. of peagravels and 0.006 cum. of coarse sand (FM=2.0 to 2.8) mixed with @ 80kg. of bitumen per cum. of peagravels and @ 96kg. of bitumen per cum.of coarse sand and laid over 1.0 sqm. of road surface including spreading with proper camber and blinding with dry sand(FM \geq 0.80) @ 0.01 cum. per sqm. including cost of all materials and incidental charges, heating bitumen 170 deg. C. to 190 deg.C temperature, rolling with 8 to 10 M. tons power driven road roller etc. complete including supply of all materials and equipments and as per direction of Engineer in charge.	sqm

ITEM DEFINITION REPORT

ItemCode	Item Description	Unit Meas.
56-420	Providing expansion/ contraction joint in concrete road, with 1.58 mm thick card board coated hot bitumen, graded 80/100 and filling gaps with bitumen etc. complete including supply of all materials and as per direction of Engineer in charge.	m
56-430	Filling up the expansion joints by asphalt, sand and jute waste etc. complete including supply of all materials and as per direction of Engineer in charge.	m

ITEM DEFINITION REPORT

ItemCode	Item Description	Unit Meas.
60 . Drain Construction		
60-100	Construction of masonry surface drain, with 75mm thick brick work with first class brick on one brick flat soling at base, all set in sand (FM \geq 1.5) cement mortar (1:4), 12mm thick sand (FM \geq 1.3) cement plaster (1:3), including rounding corners and necessary earth work, ramming and watering etc. complete (average depth 25cm, bottom width 22cm and top width 45cm) including the cost of all materials as per direction of Engineer in charge.	m
60-110	Construction of masonry surface drain with 125mm thick brick work with first class brick on one brick flat soling at base, all set in sand (FM \geq 1.5) cement mortar (1:4), 12mm thick sand (FM \geq 1.3) cement plaster (1:3), including rounding corners and necessary earth work, ramming and watering etc. complete (average depth 25cm bottom width 30cm and top width 30cm) including the cost of all materials as per direction of Engineer in charge.	m
60-120	Construction of masonry surface drain with 125mm thick brick work with first class bricks on one brick flat soling at base, all set in sand (FM \geq 1.5) cement mortar (1:4), 12mm thick sand (FM \geq 1.3) cement plaster (1:3), including rounding corners and necessary earth work, ramming and watering etc. complete (average depth 45cm, bottom width 38cm and top width 50cm) including the cost of all materials as per direction of Engineer in charge.	m
60-130	Construction of masonry surface drain with 125mm thick brick work, with first class bricks, all set in sand (FM \geq 1.5) cement mortar (1:4) and 10cm thick cement concrete (1:2:4) (sand of FM \geq 1.5, 20mm down graded brick chips) at bottom over a brick flat soling, 12mm thick sand (FM \geq 1.3) cement plaster (1:3), including rounding corners, necessary earth work, ramming, watering etc. complete (average depth 50cm, bottom width 30cm and top width 30cm) including the cost of all materials as per direction of Engineer in charge.	m
60-140	Construction of masonry surface drain with 250mm thick brick work with 1st class brick, all set in sand (FM \geq 1.5) cement mortar (1:4) and 10cm thick cement concrete (1:2:4) (sand of FM \geq 1.5, 20mm down graded brick chips) at bottom over a brick flat soling, 12mm thick sand (FM \geq 1.3) cement plaster (1:3), including rounding corners, necessary earth work, ramming, watering etc. complete (average depth 75cm, bottom width 45cm and top width 75cm) including the cost of all materials as per direction of Engineer in charge.	m
60-150	Construction of average 30cm wide and 20cm deep "V" shaped drain, with 75mm thick brick lining, with 1st class bricks, set in cement pointing (1:3) (sand of FM \geq 1.3) and rounding corners with cement mortar (1:3) etc. complete including the cost of all materials as per direction of Engineer in charge.	m
60-160	Construction of average 30cm wide and 20cm deep wide "V" shaped drain with 75mm thick brick lining with 1st class bricks, set in sand (FM \geq 1.5) cement mortar (1:3), with 12mm thick sand (FM \geq 1.3) cement plaster (1:3), rounding corners etc. complete including the cost of all materials as per direction of Engineer in charge.	m

ITEM DEFINITION REPORT

ItemCode	Item Description	Unit Meas.
60-220	Cement Concrete lining of irrigation Canal bed and slope of different thickness with 20 mm down graded picked jhama/ 1st. class brick chips/ stone shingles and sand of FM \geq 1.5, including breaking, screening, grading and washing the chips with clean water, mixing laying in position, consolidation to levels curing with supply of all materials including the cost of shuttering and forms etc. including preparation of bed and slope by cutting/ filling as per requirement true to level, grade and camber, ramming the bed, slope etc. for proper compaction complete, as per direction of Engineer in charge.	sqm
60-220-10	In leanest mix. 1:2:4 with picked jhama/1st. class brick chips; 50mm thick.	sqm
60-220-20	In leanest mix. 1:2:4 with picked jhama/1st. class brick chips; 75mm thick.	sqm
60-220-30	In leanest mix. 1:3:6 with picked jhama/1st. class brick chips; 50mm thick.	sqm
60-220-40	In leanest mix. 1:3:6 with picked jhama/1st. class brick chips; 75mm thick.	sqm
60-220-50	In leanest mix. 1:2:4 with stone shingles; 50mm thick.	sqm
60-220-60	In leanest mix. 1:2:4 with stone shingles; 75mm thick.	sqm
60-220-70	In leanest mix. 1:3:6 with stone shingles; 50mm thick.	sqm
60-220-80	In leanest mix. 1:3:6 with stone shingles; 75mm thick.	sqm
60-240	Brick lining (75mm thick) in irrigation canal bed and side slope with 1:4 sand cement mortar including soaking bricks in clean water for 6 hours, cleaning the bricks, curing at least for 7 days with supply of all materials etc. complete as per design specification and direction of Engineer in charge.	sqm
60-240-10	With first class bricks.	sqm
60-240-20	With 2nd. class bricks.	sqm
60-260	Manufacturing and Supplying Standard machine made RCC pipe of different diameter, length and thickness in construction of Drain/ Sluice/ Culvert/ Outlet and any other works in leanest mix. 1:1.5:3 with 12mm/20mm down graded stone chips, sand of FM \geq 2.0 and admixture (water reducing plasticiser) @ 1.5 litre per cubic meter of concrete to attain a minimum 28 days cylinder strength of 25 N/mm ² including breaking, screening, grading and washing aggregates with clear water, mixing, laying in forms, consolidating, curing including the cost of 6mm dia M.S. work for reinforcement and form works as per approved drawing and specification including tools, plants, testing, stacking in measurable stack etc. complete as per direction of Engineer in charge.	m
60-260-05	RCC Pipe : 100mm dia, wall thickness not less than 25mm, circular reinforcement 100mm c/c and longitudinal reinforcement 75mm c/c.	m
60-260-10	RCC Pipe : 150mm dia, wall thickness not less than 25mm, circular reinforcement 100mm c/c and longitudinal reinforcement 110mm c/c.	m
60-260-15	RCC Pipe : 225mm dia, wall thickness not less than 30mm, circular reinforcement 100mm c/c and longitudinal reinforcement 135mm c/c.	m

ITEM DEFINITION REPORT

ItemCode	Item Description	Unit Meas.
60-260-20	RCC Pipe : 300mm dia, wall thickness not less than 45mm, circular reinforcement 100mm c/c and longitudinal reinforcement 225mm c/c.	m
60-260-25	RCC Pipe : 450mm dia, wall thickness not less than 50mm, circular reinforcement 100mm c/c and longitudinal reinforcement 225mm c/c.	m
60-260-30	RCC Pipe : 500mm dia, wall thickness not less than 55mm, circular reinforcement 100mm c/c and longitudinal reinforcement 220mm c/c.	m
60-260-35	RCC Pipe : 600mm dia, wall thickness not less than 60mm, circular reinforcement 95mm c/c and longitudinal reinforcement 210mm c/c.	m
60-260-40	RCC Pipe : 750mm dia, wall thickness not less than 70mm, circular reinforcement 85mm c/c and longitudinal reinforcement 200mm c/c.	m
60-260-45	RCC Pipe : 900mm dia, wall thickness not less than 90mm with circular reinforcement for inner case 90mm c/c, outer case 100mm c/c and longitudinal reinforcement 150mm c/c.	m
60-260-50	RCC Pipe : 1050mm dia, wall thickness not less than 95mm with circular reinforcement for inner case 80mm c/c, outer case 100mm c/c and longitudinal reinforcement 140mm c/c.	m
60-260-55	RCC Pipe : 1200mm dia, wall thickness not less than 100mm with circular reinforcement for inner case 60mm c/c, outer case 100mm c/c and longitudinal reinforcement 130mm c/c.	m
60-260-60	RCC Pipe : 1350mm dia, wall thickness not less than 115mm with circular reinforcement for inner case 50mm c/c, outer case 90mm c/c and longitudinal reinforcement 125mm c/c.	m
60-280	Manufacturing and supplying standard machine made RCC Socket of different diameter, 125mm length and 50mm wall thickness in construction on Drain/ Sluice/ Culvert/ outley and any other works in leanest mix. 1:1.5:3 with 12mm down graded stone chips, sand of FM \geq 2.0 and admixture (water reducing plasticiser) @ 1.5 liters per cubic meter of concrete to attain a minimum 28 days cylinder strength of 25.0 N/mm ² including screening, grading and washing aggregates with clear water, mixing, laying in forms, consolidating, curing including the cost of formwork, 3 Nos circular reinforcement and 5 Nos longitudinal reinforcement of 6mm dia M.S. rod equally spaced as per approved drawing and specification including tools, plants, testing, stacking in measurable stack at etc. complete as per direction of Engineer in charge.	each
60-280-05	RCC Socket : 170mm dia.	each
60-280-10	RCC Socket : 220mm dia.	each
60-280-15	RCC Socket : 305mm dia.	each

ITEM DEFINITION REPORT

ItemCode	Item Description	Unit Meas.
60-300	Laying in position standard machine made R.C.C. pipe of different diameter in construction of drain/ sluice/ culvert/ outlet and any other work including fitting, fixing the socket where necessary, local handling, cutting, dressing, levelling, plumbing etc. complete as per design, specification and direction of Engineer in charge.	m
60-300-05	100mm dia.	m
60-300-10	150mm dia.	m
60-300-15	225mm dia.	m
60-300-20	300mm dia.	m
60-300-25	450mm dia.	m
60-300-30	500mm dia.	m
60-300-35	600mm dia.	m
60-300-40	750mm dia.	m
60-300-45	900mm dia.	m
60-300-50	1050mm dia.	m
60-300-55	1200mm dia.	m
60-300-60	1350mm dia.	m
60-330	Manufacturing, supplying and laying in position 25mm thick pre-cast ferrocement sheet in lining of irrigation canal bed and slope in leanest mix 1:2 (cement:sand) with sand of FM \geq 2.00 to attain a minimum 28 days cylinder strength of 18.0 N/mm ² including screening, grading and washing aggregates with clear water, mixing, laying in forms, consolidating, curing, testing, placing wire mesh (20mm mesh,18 BWG wire, 2 layers) in position as per approved design and drawing including tools, plants, preparation of platforms, shuttering (timber shutter) and staking in measurable stacks including cost of all materials and labours for preparation of bed and slope of canal and placing in position including joining with the adjacent sheet etc complete as per direction of Engineer in charge.	sqm

ITEM DEFINITION REPORT

ItemCode	Item Description	Unit Meas.
64 . Building Construction		
64-100	Lay-out of building works as per approved plan with 50mmx 50mmx 300mm wooden pegs, nails, nylon ropes, checking the dimensions, marking the excavation edges with chalk powder and maintaining the centre line pegs till completion of foundation works upto a safe level etc. complete including the cost of all materials as per direction of Engineer in charge.	sqm
64-110	Damp proof coarse (D.P.C) in proportion 1:2:4 with pudlo mixed @ 2.25kg per bag of cement over a hot bitumen coat with 12mm down graded picked jhama chips and coarse sand (FM>1.5); properly washed and screened including breaking chips, mixing, laying finishing, curing, including the cost of all materials etc. complete as per direction of Engineer in charge.	sqm
64-110-10	Minimum 40mm thick.	sqm
64-110-20	Minimum 25mm thick.	sqm
64-120	Artificial patent stone flooring with picked jhama chips, coarse sand (FM>=1.5) and cement in proportion 1:2:4, including breaking bricks, screening, washing coarse and fine aggregates, mixing, laying in blocks, compacting etc. complete as per direction of Engineer in charge.	sqm
64-120-10	Minimum 25 mm thick	sqm
64-120-20	Minimum 40mm thick	sqm
64-130	Neat cement finish on patent stone surfaces just after initial setting of concrete in all floors including curing for at least 14 days with supply of all materials etc complete as per direction of Engineer in charge.	sqm
64-140	200mmx200mmx20mm mosaic terrazo tiles flooring having 10mm thick finished mosaic top with one part of 10mm down graded marble chips and one part of mixture containing white cement and grey cement in proportion 9:1 including preparation of mix, machine pressed on 12mm thick cement mortar base (1:2) including preparing the base, setting the tiles on minimum 40mm thick cement slurry and lime and surki in proportion 1:3, compacting, cutting with pumic stone and finishing with oxalic acid including screening, washing mosaic chips and supply of all necessary materials etc. complete in all respects as per direction of Engineer in charge.	sqm
64-150	200mmx200mmx20mm silver grey mosaic terrazo tiles flooring having 10mm thick finished mosaic top with one part of 10mm down graded marble chips and one part of mixture containing white cement and grey cement in proportion 1:1, including preparation of mix, machine pressed on 12mm thick cement mortar base (1:2),preparing the base, setting the tiles on minimum 40mm thick cement slurry and lime and surki in proportion 1:3, compacting, cutting with pumic stone and finishing with oxalic acid, including screening, washing mosaic chips including the cost of all necessary materials etc complete as per direction of Engineer in charge.	sqm

ITEM DEFINITION REPORT

ItemCode	Item Description	Unit Meas.
64-160	Supplying, fitting and fixing glazed tiles of approved size, colour, quality and design in floors/ walls upto required length, breadth and height, set in 20mm thick cement mortar (1:4), including cutting & edging the tiles where necessary filling the joints by white cement and matching colour including the cost of all materials etc. complete as per direction of Engineer in charge.	sqm
64-160-10	Various size (in walls).	sqm
64-160-20	Various size (on floors).	sqm
64-170	10mm thick finished silver grey cast in situ mosaic work on floor with one part of marble chips and one part of mixture containing white cement and grey cement in proportion 1:1 including preparation of mixture and laying the same over artificial patent stone flooring including making suitable panel by 5mm thick and 20mm deep glass dividers, compacting, curing at least 7 days, cutting with pumic stone and finishing with oxalic acid, screening, washing mosaic chips including the cost of all materials but excluding the cost of patent stone etc. complete as per direction of Engineer in charge.	sqm
64-180	10mm thick cast in situ mosaic work on floor with one part of marble chips and one part of mixture containing white cement and grey cement in proportion 9:1 including preparation of mix, and laying the same over artificial patent stone flooring including making suitable panel by 5mm thick and 20mm deep glass dividers, compacting, curing at least for seven days, cutting with pumic stone and finishing with oxalic acid, screening, washing mosaic chips including the cost of all necessary materials but excluding the cost of patent stone etc complete as per direction of Engineer in charge.	sqm
64-190	6mm thick (finished) cast in situ mosaic of approved colour with marble chips, white cement, portland cement, colouring materials in proportion 5:3:2:0.25, laying in block by block, compacting, curing, maintaining proper slope and polishing the top with pumic stone, finishing with oxalic acid etc complete in all floors including the cost of all materials and as per direction of Engineer in charge.	sqm
64-200	6mm thick (finished) silver grey cast in situ mosaic with marble chips, white cement and portland cement in proportion 5:3:2, laying in block by block, compacting, curing, maintaining proper slope and polishing the top with pumic stone, finishing with oxalic acid etc complete in all floors including the cost of all materials and as per direction of Engineer in charge.	sqm
64-210	3mm thick red oxide or any colour finishing on patent stone or plaster surface including finishing, polishing, curing etc complete in all floors including the cost of all materials but excluding the cost of patent stone or plaster, as per direction of Engineer in charge.	sqm
64-210-10	Proportion 1:3 (cement:colour).	sqm
64-210-20	Proportion 1:4 (cement:colour).	sqm

ITEM DEFINITION REPORT

ItemCode	Item Description	Unit Meas.
64-400	Supplying double tarzah single layer fixed ceiling, diagonally woven, fitting, fixing etc with 2.5cmx5.0cm wooden battens of best quality local seasoned hard wood, not more than 1m apart both ways, with necessary screws, nails etc. complete including the cost of all materials, as per direction of Engineer in charge.	sqm
64-420	Supplying, fitting and fixing 3mm thick hard board ceiling, with best quality local hard wood batten 6.50cmx2.0cm size, not more than 80 cm apart both ways, with necessary screws, nails etc. complete including the cost of all materials, as per direction of Engineer in charge.	sqm
64-430	Supplying, fitting and fixing 12mm thick plain partex board in ceiling with well seasoned garjan wood frame of section 75mmx40mm at 600mmx600mm in grid, suspended from ceiling/roof or beam by 12 SWG double ply G.I.Wire fixed in the ceiling by rowel plug, screws, hooks, nails etc maintaining straight lines and desired finished level at bottom face with vertical strut as required including cutting holes in slabs or beams by drill machine and mending good the damages with supply of all materials, accessories, labour for installation, scaffolding, screws, nails etc. complete including the cost of all materials, as per direction of Engineer in charge.	sqm
64-440	Supplying, fitting and fixing 12mm thick plain partex board in walling with well seasoned garjan wood frame of section 75mmx40mm at 600mmx600mm in grid, fitted and fixed to wall by plugs, nails, screws etc maintaining straight lines, levelled, finished and desired exposed faces including cutting holes in walls and mending good the damages with supply of all materials, accessories, labour for installation, scaffolding etc. including the cost of all materials etc. complete as per direction of Engineer in charge.	sqm
64-460	Supplying and fitting fixing 12mm thick plain partex board in ceiling with aluminium frame of section 25mmx25mmx1.0mm angles and Tees made with high strength entruded section of aluminium alloy with anodic oxide hard core coating of 10 microns on all exposed faces, at 600mmx600mm in grid, suspended from ceiling/ roof or beam by 12 SWG double ply G.I.Wire fixed to the ceiling by rowel plug, screws, hooks, nails etc maintaining straight lines and desired finish level at bottom face including cutting holes in slabs or beams by drill machine and mending good the damages including cost and carriages of all materials accessories, labour for installation, scaffolding etc. all complete including the cost of all materials, as per drawing and direction of Engineer in charge.	sqm
64-470	Supplying fitting and fixing of aluminium door, aluminium sliding/ hinged/ fixed windows and partition doors having high strength extruded section made of aluminium alloy having a minimum section thickness of 1.8mm unless otherwise shown in drawing, all the exposed surfaces shall be given a dark bronze anodic oxide hardcore coating of 10 microns in thickness and uniform colour tone conforming to the approved sample with all necessary locks, handles, 5mm thick glass panes and all other accessories for fitting fixing including neoprene weather strips and sealing joints between frames etc. complete including the cost of all materials as per drawing and direction of Engineer in charge.	sqm

ITEM DEFINITION REPORT

ItemCode	Item Description	Unit Meas.
64-470-10	Double swing door.	sqm
64-470-20	Swing door with locking arrangement.	sqm
64-470-30	Sliding window with locking arrangement.	sqm
64-470-40	Fixed door frame.	sqm
64-470-50	Hinged window.	sqm
64-480	Supplying fitting & fixing of standard uPVC (Plastic Door) Door of different sizes with 4 nos 3" hinges, 2nos 4" tower bolt, 2nos 6" handle and one no standard lock including all accessories complete as per direction of the Engineer-in-charge.	sqm
64-500	Supplying, fitting and fixing C.I. sheet roofing, with G.I. nuts, limped, washers, screws, bolts etc. and fitting, fixing with 76mm hooks with at least 2 pitch lapping etc. complete, including the cost of all materials as per direction of Engineer in charge.	sqm
64-500-10	0.63mm or 24 BWG C.I. sheet.	sqm
64-500-20	0.50mm or 26 BWG C.I. sheet.	sqm
64-510	Supplying, fitting and fixing C.I. sheet walling, with G.I. nuts, limped, washers, screws, bolts etc. including the cost of all materials and fitting, fixing with 76mm hooks with at least 2 pitch lapping etc. complete, as per direction of Engineer in charge.	sqm
64-510-10	0.63mm or 24 BWG C.I. sheet.	sqm
64-510-20	0.50mm or 26 BWG C.I. sheet.	sqm
64-530	Supplying, fitting and fixing G.I or C.I. ridging or gutting (24 BWG) with bolts, washers, screws, etc. complete including cost of all materials as per direction of Engineer in charge.	sqm
64-550	Supplying, fitting & fixing coloured Translucent corrugated sheet made of UV resistant resin in roofing/walling with all nuts & bolts, washers, screws etc. and fitting, fixing with 75mm hooks with at least 2 pitch lapping etc. complete including the cost of all materials as per direction of Engineer in charge.	sqm
64-550-10	2mm thick.	sqm
64-550-20	3mm thick.	sqm
64-560	Supplying, fitting & fixing 2-3 mm thick coloured Translucent sheet made of UV resistant resin in ridging or gutting with all nuts & bolts, washers, screws etc. complete including the cost of all materials as per direction of Engineer in charge.	sqm

ITEM DEFINITION REPORT

ItemCode	Item Description	Unit Meas.
64-580	Replacing glass panes in door and window shutters including removing, clearing old (broken) panes in steel or wooden shutters including supply of all materials such as putty, beat, glass panes of required size etc. complete in all respect as per direction of Engineer in charge.	sqm
64-580-10	With 3mm thick glass.	sqm
64-580-20	With 5mm thick glass.	sqm
64-610	Labour charge for taking out C.I. sheet and refitting with old and new C.I. sheet with supply of necessary bolts, screws, washers etc. complete as per direction of Engineer in charge.	sqm
64-610-10	From roof.	sqm
64-610-20	From wall.	sqm
64-620	Labour charge for fitting and fixing ridges and gutters with bolts, screws, washers etc. complete as per direction of Engineer in charge.	m
64-650	Supplying, fitting and fixing steel glazed window shutters with frames as per design having 19mmx 19mmx 3mm "Z" section in frame and "T" section for horizontal dividers of shutters and 25mmx 3mm F.I. bar for middle vertical members of frames including all charges for fabrication & manufacture by welding, rivetting etc. with supply of all essential fittings like stopper, handle, 250mm long adjustable cleats, iron pins, hinges, clamps, 3mm glass panes by pucca putty and painting the window with two coats of synthetic enamel paint over a coat of anticorrosive priming, making necessary holes in walls and R.C.C. works as necessary filling with C.C. (1:2:4) and mending good the damages including all cost of material, carriage and labour in fitting, fixing etc. all complete as per drawing, design and direction of Engineer in charge.	sqm
64-660	Manufacturing, supplying, fitting and fixing of fixed glazed frame with outer member of 19mm x 19mm x 3mm "Z" section in frame and "T" section for horizontal dividers of 19mm x 19mm x 3mm "T" section including all cost of fabrication and welding, supplying and fixing of clamps of required nos. with the frame, fixing the frame in wall with 1:2:4 C.C. after making necessary grooves, supplying and fixing of 3mm glass panes with pucca putty, mending good all damages, painting iron faces with two coats of synthetic enamel paint over a coat of anticorrosive priming of approved colour and quality etc. complete including the cost of all materials as per direction of Engineer in charge.	sqm
64-680	Fitting, fixing of pre cast ventilator minimum 25mm thick of any design, with cement mortar (1:3) fitted and fixed in position, finished with cement plaster (1:6) including necessary scaffolding, curing etc. complete in all floors including the cost of all materials as per direction of Engineer in charge.	sqm

ITEM DEFINITION REPORT

ItemCode	Item Description	Unit Meas.
64-690	Reinforced Cement Concrete works (building works) in leanest mix. 1:2:4, in foundation and plinth, with 20mm down graded coarse aggregates and sand of FM>1.5, to attain a minimum 28 day cylinder strength of 16.0 N/sq.mm, including breaking, screening, grading and washing aggregates with clear water, mixing, laying in forms, consolidation to levels, curing, including the cost of all materials, excluding the cost of M.S. work for reinforcements and formworks etc. complete as per direction of Engineer in charge.	cum
64-690-10	With picked jhama or 1st. class brick chips.	cum
64-690-20	With stone chips.	cum
64-690-30	With stone shingles.	cum
64-700	Reinforced cement concrete work (building works) in leanest mix 1:2:4, in foundation and plinth, with 20mm down graded coarse aggregates and sand of FM>1.8 to FM<=2.5, to attain a minimum 28 day cylinder strength of 18.0 N/sq.mm, including breaking, screening, grading, washing aggregates with clear water, mixing, laying in forms, consolidation to levels, curing, including the cost of all materials, excluding the cost of M.S. work for reinforcements and formworks etc. complete as per direction of Engineer in charge.	cum
64-700-10	With picked jhama or 1st. class brick chips.	cum
64-700-20	With stone chips.	cum
64-700-30	With stone shingles.	cum
64-710	Reinforced cement concrete work (building works) in leanest mix 1:1.5:3, in foundation and plinth, with 20mm down graded coarse aggregates and sand of FM>2.0 to FM<=2.5, to attain a minimum 28 day cylinder strength of 22.0 N/sq.mm, including breaking, screening, grading, washing aggregates with clear water, mixing, laying in forms, consolidation to levels, curing, including the cost of all materials, excluding the cost of M.S. work for reinforcements and formworks etc. complete as per direction of Engineer in charge.	cum
64-710-10	with stone chips.	cum
64-710-20	with stone shingles.	cum
64-720	Extra rates for R.C.C in superstructures in different stories over the rate of R.C.C work in foundation and plinth.	cum
64-720-10	Ground floor superstructure.	cum
64-720-20	First floor superstructure.	cum
64-720-30	Second floor superstructure.	cum
64-720-40	Third floor superstructure and above.	cum

ITEM DEFINITION REPORT

ItemCode	Item Description	Unit Meas.
64-730	Average 80mm thick (beaten) lime terracing in roof with 25mm down graded 1st class brick chips, surki from 1st class bricks and lime, in proportion 7:2:2, including breaking chips, screening, mixing, laying to slopes, compacting and finishing with 6mm thick lime slurry (1:4), molasses and watering, making ghoondy, curing etc. complete with including the cost of all materials as per direction of Engineer in charge.	cum
64-730-10	Ground floor roof.	cum
64-730-20	Extra rate for above work for each additional storey.	cum
64-750	Repairing leakage in roof slab by applying bitumen emulsion (bitumen content not less than 57%) in 5 coats; the 1st coat being 1.51 kg/sqm, the 2nd coat 1.18 kg/sqm and the rest 3 coats each being 0.97 kg of bitumen emulsion per sqm to be subsequently applied; including scraping, removing moss, cleaning the roof surface by steel wire brush, brooming and drying & cleaning the bitumenous coat at every sequance including sand (FM \geq 1.5) blinding by 0.0030 cum per sqm on each bituminous coat including the cost of all labours, materials, staggng, implements etc. complete in all respects as per direction of Engineer in charge.	sqm

ITEM DEFINITION REPORT

ItemCode	Item Description	Unit Meas.
68 . Wood Work		
68-100	Supplying wooden flap gates with pressure treated Sundari, Garjan, Shishu or equivalent timber for regulator/ sluices, as per approved drawing, specification and direction of Engineer in charge.	each
68-100-10	0.75m dia to 1.20m dia with 40mm thick plank and 3 nos 50mmx75mm batten.	each
68-100-20	Above 1.20m dia with 50mm thick plank and 3 nos 50mmx75mm batten.	each
68-130	Supplying pressure treated wooden fall boards/stop logs of different sizes (not less than 15cm in depth) of sal, sundari, garjan, shishu or equivalent for regulator/ sluices, including fixing in position with eye hook etc. complete as per direction of Engineer in charge.	cum
68-180	Supplying wooden folding camp table of size 0.90mx 0.75mx 0.75m, made of well seasoned jack/ shilkarai or equivalent wood (free from saps) including polishing etc. complete as per direction of Engineer in charge.	each
68-190	Supplying wooden office table of size 1.20mx 0.75mx 0.75m, with two drawers, made of well seasoned jack/ shilkarai or equivalent wood (free from saps) including polishing etc. complete as per direction of Engineer in charge.	each
68-210	Supplying typist table, 1.50mx0.75mx0.75m size made of well seasoned Jack/ shilkarai or equivalent wood (free from saps) including sand papering, polishing etc. complete (25mm thick plank) as per direction of Engineer in charge.	each
68-220	Supplying secretariat table made of well seasoned Jack/ shilkarai or equivalent wood (free from saps) with reksin top, including sand papering, polishing etc. complete as per direction of Engineer in charge.	each
68-220-10	Half secretariat table : 1.20mx1.00mx0.75m size.	each
68-220-20	Full secretariat table : 1.50mx1.00mx0.75m size.	each
68-230	Supplying standard size wooden armed chair of approved quality, made of well seasoned jack/ shilkarai wood (free from sap), including sand papering, polishing etc. complete as per direction of Engineer in charge.	each
68-230-10	Wooden seated.	each
68-230-20	Natural cane seated.	each
68-230-30	Synthetic cane seated.	each
68-240	Supplying standard size armless chair, made of well seasoned) Jack/ silkarai wood (free from saps), including sand papering, polishing etc. complete as per direction of Engineer in charge.	each
68-240-10	Wooden seated.	each
68-240-20	Natural cane seated.	each
68-240-30	Synthetic cane seated.	each

ITEM DEFINITION REPORT

ItemCode	Item Description	Unit Meas.
68-250	Supplying wooden what not of size 0.90mx0.75mx0.35m with 3 shelves, made of well seasoned Jack/ Garjan wood, (free from saps), including polishing etc. complete as per direction of Engineer in charge.	each
68-260	Supplying wooden long bench of standard size (1.60m long), made of well seasoned Jack/ shilkorai wood, (free from saps), including polishing etc. complete as per direction of Engineer in charge.	each
68-260-10	without back	each
68-260-20	with back	each
68-270	Supplying wooden notice board of size 1.20mx 0.75mx 0.15m, made of well seasoned Silkarai/ Jack wood, with 12mm thick soft pertex board at back, hinged shutter with locking arrangement having galvanizsd steel ornamesh (9mmx29mm mesh, 0.5mm thick) covering etc. complete with polishing and necessary arrangement for hanging etc complete as per direction of Engineer in charge.	each
68-280	Supplying wooden tender box, 450mmx 600mmx 900mm size, made with minimum 25mm thick plank (finished) of well seasoned shilkarai, shisu or equivalent wood (free from saps) including necessary locking arrangements, sand papering, polishing etc. complete as per direction of Engineer in charge.	each
68-290	Supplying wooden stool of standard size, made of well seasoned jack/ shilkarai or equivalent wood (free from saps) including sand papering, polishing etc. complete as per direction of Engineer in charge.	each
68-300	Supplying wooden file rack of size 2.15m x1.50m x0.45m, with 5 shelves, made of well seasoned jack/ shilkarai or equivalent wood (free from saps) including sand papering, polishing etc. complete as per direction of Engineer in charge.	each
68-310	Supplying dustbin/ waste paper basket of standard size as per direction of Engineer in charge.	each
68-310-10	Wooden dustbin.	each
68-310-20	Plastic waste paper basket.	each
68-350	Supplying, fitting and fixing 40mm thick (finished) single leaf, well seasoned flush door shutters, having top and bottom rails of section 100mmx40mm, styles 100mmx40mm, lock rail 100mmx40mm, covered with 13mm thick planks screwed to each other with close tongue and groove joints, including the cost of all materials such as screws, 2 nos 150mm and 150mm long tower and socket bolts, 4 nos 100mm hinges, 2 nos heavy type nickel plated handles, hinged cleats etc. complete, finished with sand papering for all floors and as per drawing and direction of Engineer in charge.	sqm
68-350-10	With kathal or Chapalish wood.	sqm
68-350-20	With Gammar wood.	sqm

ITEM DEFINITION REPORT

ItemCode	Item Description	Unit Meas.
68-350-30	With Teak Chambol wood.	sqm
68-350-40	With Chittagong Teak wood.	sqm
68-390	Supplying, fitting and fixing 40mm thick (finished) seasoned wood grooved panel flush door shutters, having top, bottom, lock rails and styles of section 100mmx40mm and vertical panels 100mmx40mm including keeping 6mmx12mm grooved lap to each panel, providing 4 nos 100mm long iron hinges, 2 nos 300mm and 225mm long iron socket and tower bolts, 2 nos heavy type nickel plated handles, hinged cleats and finished with necessary sand papering for all floors etc. complete including the cost of all materials as per direction of Engineer in charge.	sqm
68-390-10	With Kathal or Chapalish wood.	sqm
68-390-20	With Gammar wood.	sqm
68-390-30	With Chittagong Teak wood.	sqm
68-400	Supplying, fitting and fixing 40mm thick (finished) seasoned wood double leaf panel door shutters, top rail and styles of section 100mmx40mm, lock rail 125mmx40mm and bottom rail 225mmx40mm, panelling 40mm thick (finished), both sides raised, provided with 6 nos 100mm long iron hinges, 2 nos 300mm and 225mm long iron socket and tower bolts, 2 nos heavy type nickel plated handles, hinged cleats, buffer blocks and finished with necessary sand papering for all floors etc. complete including the cost of all materials as per direction of Engineer in charge.	sqm
68-400-10	With Kathal or Chapalish wood.	sqm
68-400-20	With Gammar wood.	sqm
68-400-30	With Teak Chambol wood.	sqm
68-400-40	With Chittagong Teak wood.	sqm
68-410	Supplying, fitting and fixing 40mm thick (finished) seasoned wood panel door shutters, having top rails and styles of section 100mmx40mm, lock rail 125mmx40mm and bottom rail 225mmx40mm, panelling 40mm thick (finished), both sides raised, provided with 6 nos 100mm long iron hinges, 2 nos 300mm and 225mm long iron socket and tower bolts, 2 nos heavy type nickel plated handles, hinged cleats and finished with necessary sand papering for all floors (double leaf) etc. complete including the cost of all materials as per direction of Engineer in charge.	sqm
68-410-10	With Kathal or Chapalish wood.	sqm
68-410-20	With Gammar wood.	sqm
68-410-30	With Teak Chambol wood.	sqm
68-410-40	With Chittagong Teak wood.	sqm

ITEM DEFINITION REPORT

ItemCode	Item Description	Unit Meas.
68-430	25mm single leaf well seasoned wooden shutters of local wood (Jack, garjan), free from saps or knots, having 60mmx25mm size (finished section) Z-battens, with necessary screws, 3 nos 100mm long iron hinges, 2 nos 150mm and 150mm long iron socket and tower bolts, 2 nos rings 50mm dia for locking, hinged cleats, finished with sand papering etc. complete, for all floors including the cost of all materials as per direction of Engineer in charge.	sqm
68-450	Supplying, fitting and fixing 40mm thick chambol/gammar/ chapalish or equivalent veneered door shutters with supply of all necessary fittings and accessories such as screws, 4 nos 100mm long iron hinges, 2 nos 300mm and 225mm long iron socket and tower bolts, 2 nos heavy type nickel plated handles, hinged cleats etc complete in all floors including the cost of all materials as per direction of Engineer in charge.	sqm
68-500	Supplying, fitting and fixing 40mm thick (finished) well seasoned wood, glazed window shutters, having horizontal and vertical section of 90mmx40mm size, sash bar 40mmx40mm, fitted with 3mm glass panes with putty and nails and provided with 4 nos 75mm long iron hinges, 2 nos 250mm and 150mm long iron tower and socket bolts, nickel plated handles, 225mm long catch hooks, hinged cleats and finished with necessary sand papering for all floors etc. complete including the cost of all materials as per direction of Engineer in charge.	sqm
68-500-10	With Kathal or Chapalish wood.	sqm
68-500-20	With Gammar wood.	sqm
68-500-30	With Teak Chambol wood.	sqm
68-500-40	With Chittagong Teak wood.	sqm
68-520	Supplying, fitting and fixing 40mm thick (finished) well seasoned wood window shutters, one third glazed and 40mm thick two third both sides raised panelling having horizontal and vertical section of 90mmx40mm, sash bars 40mmx40mm, fitted with 3mm glass panes with putty and nails and provided with 4 nos 75mm long iron hinges, 2 nos 250mm and 150mm long iron tower and socket bolts, nickel plated handles, 225mm long catch hooks, hinged cleats and finished with necessary sand papering for all floors etc. complete including the cost of all materials as per direction of Engineer in charge.	sqm
68-520-10	With Kathal or Chapalish wood.	sqm
68-520-20	With Gammar wood.	sqm
68-520-30	With Teak Chambol wood.	sqm

ITEM DEFINITION REPORT

ItemCode	Item Description	Unit Meas.
68-540	Wood work in door and window frames with best quality well seasoned wood, free from sap or knots, including painting 2 coats of paints to the face in contact with walls, finishing, cutting grooves for fitting the shutters etc. and fitting fixing with 6 nos of 225mmx38mmx5mm F.I. bar clamps, fitted with frames with screws, duly embedded in walls with cement concrete (1:3:6) etc. complete in all floors including the cost of all materials as per drawing and direction of Engineer in charge.	cum
68-540-10	With Jam or Kathal wood.	cum
68-540-20	With Silkarai, Jarul or local sal wood.	cum
68-540-30	With Garjan or Sundari wood.	cum
68-540-40	With Teak Chambol wood.	cum
68-540-50	With Chittagong Teak wood.	cum
68-580	Wood work in frames of roof trusses, post, post plate, rafter purlin, wall plate etc. of required size including fitting, fixing, with nails, screws, supplying all materials, fabrication, hoisting, scaffolding etc. complete including the cost of all materials as per direction of Engineer in charge.	cum
68-580-10	With Garjan or Sundari wood.	cum
68-580-20	With Silkarai, Jarul or local sal wood.	cum
68-600	Fine and smooth finished wood work with well seasoned wood, fitting, fixing, with nails, screws etc. complete including the cost of all materials as per direction of Engineer in charge.	cum
68-600-10	With Silkarai or Jarul wood.	cum
68-600-20	With Teak Chambol wood.	cum
68-600-30	With Chittagong Teak wood.	cum
68-620	100mmx70mm size (finished section) wooden hand rail with well seasoned wood, for stair or verandah railing, including supply of all materials, necessary moulding, fitting, fixing etc. complete including the cost of all materials as per drawing and direction of Engineer in charge.	m
68-620-10	With Chittagong Teak wood.	m
68-620-20	With Silkarai wood.	m
68-640	Repair of door and window frames after taking out (if necessary) the frames with shutters and refixing after repairing and making good the damages in the wall etc. complete including the cost of all materials as per direction of Engineer in charge.	cum
68-640-10	With Kathal wood.	cum
68-640-20	With Silkarai, Jarul or local sal wood.	cum

ITEM DEFINITION REPORT

ItemCode	Item Description	Unit Meas.
68-640-30	With Garjan or Sundari wood.	cum
68-650	Repair of door and window shutters after taking out the shutters (if necessary) with sized wood of finished section and refixing after repairing etc. complete including the cost of all materials as per direction of Engineer in charge.	sqm
68-650-10	40mm thick panelled shutter with Jack wood.	sqm
68-650-20	40mm thick glazed shutter with Jack wood.	sqm
68-650-30	40mm thick panelled shutter with Chapalish wood.	sqm
68-650-40	40mm thick glazed shutter with Chapalish wood.	sqm

ITEM DEFINITION REPORT

ItemCode	Item Description	Unit Meas.
72 . Painting Work		
72-100	Plastic emulsion painting to walls and ceiling including sand papering the surface, scaffolding etc. complete, with all necessary lime cement putty to surface including the cost of all materials, as per direction of Engineer in charge:	sqm
72-100-10	3 coats.	sqm
72-100-20	2 coats over old surface.	sqm
72-110	Painting gauges with black, white and red water proof paint including printing letters and necessary cleaning and sand papering before printing etc. complete as per direction of Engineer in charge.	m
72-120	Synthetic enamel painting 2 coats over a priming coat, to M.S. window gratings, including scrapping, sand papering, clearing the rust if any, including the cost of all materials as per direction of Engineer in charge.	sqm
72-130	Synthetic enamel painting to steel surfaces/ gates/ hoists etc. with paint of approved colour (2 coats over a coat of priming) including preparation of the surface with steel brush, emery paper and cleaning etc. complete including the cost of all materials as per direction of Engineer in charge.	sqm
72-130-10	2 coats over a priming coat.	sqm
72-130-20	2 coats over old surface.	sqm
72-140	Synthetic enamel painting to wood works, including preparation of surface by sand paper etc. complete including the cost of all materials as per direction of Engineer in charge:	sqm
72-140-10	2 coats over a priming coat	sqm
72-140-20	2 coats over old surface	sqm
72-150	Coal tar painting 2 coats, over a coat of priming with 20% pitch, including preparation of surface (wood work) etc. complete including the cost of all materials as per direction of Engineer in charge.	sqm
72-170	Red oxide painting to brick work etc. including preparation of surface, with sand paper, iron brush etc. complete, including the cost of all materials as per direction of Engineer in charge.	sqm
72-170-10	2 coats over a priming coat.	sqm
72-170-20	1 coats over a priming coat.	sqm
72-180	Provide 1 (one) coat of Zinc phosphate as primary coat and 2 (two) coat of coaltar epoxy coat over primary coat to steel surface with paint of approved colour etc. complete including the cost of all materials as per direction of Engineer in charge.	sqm

ITEM DEFINITION REPORT

ItemCode	Item Description	Unit Meas.
72-190	White washing 1 coat with stone lime, gum etc. including cleaning the surface, sand papering, scaffolding, etc. complete in all floors, including the cost of all materials as per direction of Engineer in charge.	sqm
72-200	White washing 2 coats, over a coat of priming with stone lime, gum and blue, including cleaning the surface, sand papering, scaffolding etc. complete, in all floors including the cost of all materials as per direction of Engineer in charge.	sqm
72-200-10	over new surface.	sqm
72-200-20	over old surface.	sqm
72-220	Colour washing 2 coats, over a coat of priming white wash of approved colour with slaked stone lime, including cleaning the surface, scaffolding etc. complete in all floors, including the cost of all materials as per direction of Engineer in charge.	sqm
72-220-10	over new surface.	sqm
72-220-20	over old surface.	sqm
72-250	Snowcem painting of approved quality and colour, to out side wall, including cleaning and sand papering the surface, necessary scaffolding including curing for at least 7 days etc. complete, in all respect, including the cost of all materials as per direction of Engineer in charge.	sqm
72-250-10	2 coats over a priming coat.	sqm
72-250-20	2 coats over old surface.	sqm
72-260	Weather Coat of approved quality and colour (delivered from authorized local agent of the Manufacturer in a sealed container) on exterior surface applying as per manufacturer instructions including cleaning the surface with wire brush, provision of necessary scaffolding, cleaning doors & windows, ventilators by washing including cost of water, electricity & other charges etc. complete in all respect as per direction of Engineer in charge.	sqm
72-260-10	Applying of Weather coats to exterior surface: 2 coats	sqm
72-260-20	Applying of Weather coats to exterior surface: 3 coats	sqm
72-290	Scrapping and clearing of mosses or outside colour work or surface marks from wall and ceiling as per direction of Engineer in charge.	sqm
72-310	French polishing to the frames and shutters of doors and windows, 4 coats over a coat of priming, including preparing the surface, cleaning, finishing and polishing with sand paper etc. all complete in all floors, including the cost of all materials as per direction of Engineer in charge.	sqm
72-330	Earth oiling 2 coats including the cost of all materials as per direction of Engineer in charge.	sqm

ITEM DEFINITION REPORT

ItemCode	Item Description	Unit Meas.
72-490	Oil bound distempering to walls and ceiling with approved brand distemper over a primary coat of chalk wash with glue including cleaning, sand papering the surface and necessary scaffolding etc. complete in all floors, including the cost of all materials as per direction of Engineer in charge.	sqm
72-490-10	1 coat.	sqm
72-490-20	2 coat.	sqm
72-540	Epoxy paint 2 coats of approved colour and specification over a priming coat to gate, hoisting device and embedded metal parts including scraping out rust and old paint with chisel, scraper, steel wire brush & emery paper etc. complete in all respect including the cost of all materials as per direction of Engineer in charge.	sqm
72-550	Greasing different types of gear box of hoisting system with best quality grease including deassemble of the gear box, cleaning old grease, removing sticky materials by scraper, chisel, steel wire brush, emery cloth, diesel/kerosine and assembling the same in original level, line, grade etc. complete including the cost of all materials as per direction of Engineer in charge.	each

ITEM DEFINITION REPORT

ItemCode	Item Description	Unit Meas.
76 . M.S. Work & Metal Work		
76-100	M.S. Work for reinforcement with plain M.S. bar, $f_y=300$ N/mm ² , (made from billet) in RCC works, including local handling, cutting, forging, bending, cleaning and fabrication with supply of plain round M.S. bar in different sizes and binding with 22 to 18 gages G.I. wire etc. complete including the cost of all materials as per direction of Engineer in charge.	kg
76-100-10	6mm dia.	kg
76-100-20	9mm dia to 30mm dia.	kg
76-100-30	Above 30mm dia.	kg
76-110	M.S. Work for reinforcement with deformed M.S. bar, $f_y=300$ N/mm ² , (made from billet) in RCC works, including local handling, cutting, forging, bending, cleaning and fabrication with supply of deformed M.S. bar in different sizes and binding with 22 to 18 gages G.I. wire etc. complete including the cost of all materials as per direction of Engineer in charge.	kg
76-110-10	8mm dia to 30mm dia.	kg
76-110-20	Above 30mm dia.	kg
76-115	M.S Work for reinforcement with Standard deformed bar $f_y=300$ N/mm ² in RCC works including local handling, cutting, forging,bending,cleaning and fabrication with supply of deformed M.S. bar in different sizes and bending with 22 to 18 gages G.I. wire etc. complete including the cost of all materials as per direction of Engineer in charge.	
76-115-10	6mm dia	kg
76-115-20	8mm dia to 30mm dia	kg
76-115-30	Above 30mm dia	kg
76-120	M.S. Work for reinforcement with deformed M.S. bar, $f_y=400$ N/mm ² , (made from billet) in RCC works, including local handling, cutting, forging, bending, cleaning and fabrication with supply of deformed M.S. bar in different sizes and binding with 22 to 18 gages G.I. wire etc. complete including the cost of all materials as per direction of Engineer in charge.	kg
76-120-10	8mm dia to 30mm dia.	kg
76-120-20	Above 30mm dia.	kg
76-140	M.S. Work for reinforcement with plain M.S. bar, $f_y=248$ N/mm ² , (made from scrap) in RCC works, including local handling, cutting, forging, bending, cleaning and fabrication with supply of plain round M.S. bar in different sizes and bending with 22 to 18 gages G.I. wire etc. complete including the cost of all materials as per direction of Engineer in charge.	kg
76-140-10	6mm dia.	kg

ITEM DEFINITION REPORT

ItemCode	Item Description	Unit Meas.
76-140-20	9mm dia to 30mm dia.	kg
76-140-30	Above 30mm dia.	kg
76-170	M.S. Work in plates, angles, channels, flat bars, Tees etc. including fabricating, machining, cutting, bending, welding, forging, drilling, revetting, embedding anchor bars, staging and fitting, fixing, local handling etc. complete with energy consumption and supply of labours including the cost of materials as per design, specification and direction of Engineer in charge.	kg
76-180	Cleaning corrosion and rust from the surface of steel with power brush etc. Complete including the cost of all materials as per direction of Engineer in charge.	sqm
76-185	Cleaning corrosion, rust and old paint from the surface of steel with sand blasting with coarse sand (FM>=3) etc. Complete including the cost of all materials as per direction of Engineer in charge.	sqm
76-190	Manufacturing, supplying and Installation of Padestal type lifting device for slide gate with 63mm dia threaded steel shaft, 146mm outer dia bronze nut, thrust bearing, steel bevel gear etc. as per approved design including supply of all components, labours with a prime coat of redoxide where necessary etc. complete including the cost of all materials as per specification and direction of Engineer in charge.	each
76-200	Manufacturing, supplying and Installation of Hand Wheel type lifting device for slide gate with 63mm dia steel shaft, 108mm outer dia bronze nut taper roller bearing SKF-50216 etc. as per approved design including supply of all components, labours with a prime coat of redoxide where necessary etc. complete including the cost of all materials as per specification and direction of Engineer in charge.	each
76-230	Manufacturing, supplying, installation and fitting, fixing the vertical steel lift gate/ flap gate as per design and specification, including fabricating, rivetting, welding, fixing rubber seal, providing required nuts and bolts including the cost of all materials etc. complete with a prime coat of redoxide where necessary as per direction of Engineer in charge. (Applicable only for size not specified and smaller than size mentioned in Item code 76-240 & 76-250)	kg
76-240	Manufacturing & Supplying of M.S. Vertical Lift Gate shutter of 8mm thick M.S. skin plate and stiffener with minimum 75mmx75mmx10mm M.S. angle as frame, horizontal & vertical beam, 75mmx25mmx12mm P-type rubber seal, fixed with 10mm dia x 63.5mm M.S. counter shank bolts with nuts and 40mmx10mm M.S. strip as clamp drilled spaces @ 150mm c/c, stem attachment with proper thread, nut, cotter pin and washer as per approved design including the cost of all materials of proper grade & brand new with a prime coat of redoxide where necessary as per specification and direction of Engineer in charge.	each
76-240-10	Size 1.00m x 1.00m.	each

ITEM DEFINITION REPORT

ItemCode	Item Description	Unit Meas.
76-240-20	Size 1.35m x 1.35m.	each
76-240-30	Size 1.95m x 1.35m.	each
76-240-40	Size 1.95m x 1.65m.	each
76-250	Manufacturing & Supplying of M.S. Flap Gate shutter of 8mm thick M.S. skin plate and stiffener with minimum 75mmx75mmx10mm M.S. angle as frame, horizontal & vertical beams, 100mmx45mmx16mm P-type rubber seal, fixed with 10mm dia x 63.5mm M.S. counter sink and hex. nuts & bolts and 40mmx10mm M.S. strip as clamp drilled spaces @ 150mm c/c hinge assy with gate and wall bracket, link arm of 19mm thick M.S. plate, 4 nos 25mm dia x 150mm stainless steel hinge pin with proper thread, nut, cotter pin and washer as per approved design including the cost of all materials of proper grade & brand new with a prime coat of redoxide where necessary as per specification and direction of Engineer in charge.	each
76-250-10	Size 1.00m x 1.00m.	each
76-250-20	Size 1.35m x 1.35m.	each
76-250-30	Size 1.95m x 1.35m.	each
76-250-40	Size 1.95m x 1.65m.	each
76-260	Labour charge for fitting and fixing of M.S. vertical lift gate/ flap gate shutters of different size including making holes in concrete for hooking arrangements with supply of necessary materials, tools and other accessories required for fitting the same to regulator/sluice and mending the damages with CC (1:2:4), removing the spoils etc. complete including the cost of all materials as per direction of Engineer in charge.	each
76-260-10	Size 1.00m x 1.00m or 1.35m x 1.35m.	each
76-260-20	Size 1.95m x 1.35m or 1.95m x 1.65m.	each
76-270	Labour charge for removal of M.S.Gates and Hoists from all types of structures with all leads and lifts including hire charge of boat, chain pulley, bamboo, ropes etc. and refixing the same in original level, line and grade after painting (excluding the cost of painting) as per direction of Engineer in charge.	each
76-270-10	Large size: 1.95 m x 1.65 m or 1.95 m x 1.35 m	each
76-270-20	Small size: 1.35 m x 1.35 m or 1.00 m x 1.00 m	each
76-280	Manufacturing, supplying and installation of M.S.Embedded parts for flap/ vertical lift gate including fabricating, bending, welding, forging, drilling holes, welding anchor bars, fitting, fixing etc. complete including the cost of materials with a prime coat of red oxide where necessary as per design, specification and direction of Engineer in charge.	kg

ITEM DEFINITION REPORT

ItemCode	Item Description	Unit Meas.
76-290	Manufacturing, supplying and fitting, fixing of M.S. gratings with 25mmx25mmx6mm M.S. angle frame and 25mmx6mm F.I. bar @ 50mm c/c, lateral stiffener not more than 600mm apart and embedded frame with M.S. angle (25mmx25mmx6mm), including fabrication, welding in accordance with approved design, drawing, specification, etc. complete including the cost of all materials with a prime coat of redoxide where necessary as per direction of Engineer in charge.	sqm
76-300	M.S. railing of 0.91m height with 25mmx6mm vertical flat bar, at the rate of 100mm c/c, welded to 25mmx6.00mm flat bar at top and bottom with wooden hand rail (100mmx70mm, finished), including fitting and fixing in position with necessary clamps with a prime coat of redoxide where necessary including making holes in walls or floors where necessary and duly embedded in concrete (1:3:6), mending the damages etc. complete as per approved drawing and direction of Engineer in charge:	sqm
76-300-10	With hand rail of Chittagong Teak wood	sqm
76-300-20	With hand rail of Chittagong silkarai wood or equivalent.	sqm
76-310	0.910m high M.S. railing with 25mmx6mm vertical F.I. bar, at the rate of 100mm c/c, welded to 25mmx6mm F.I. bar at top and bottom with 40mm dia G.I. pipe hand rail, including fitting and fixing in position with necessary clamps with a prime coat of redoxide where necessary including making holes in walls or floors where necessary and duly embedded in concrete (1:3:6) mending good the damages etc. complete as per drawing and direction of Engineer in charge.	sqm
76-320	Supplying and fitting fixing M.S.Grill made of 10mm dia M.S.bar @100mm c/c both ways fitted with M.S.Angles (25mmx25mmx6mm) outer frame including fabricating, welding in each point with a prime coat of redoxide where necessary as per drawing, design etc. complete, as per direction of Engineer in charge.	sqm
76-330	M.S. work in window gratings, with 16mm dia m.s.bar @ 100mm c/c, and 3 nos F.I.horizontal bars (40mmx6mm size), fitted and fixed in position, including necessary drilling, fabricating, welding, screwing with a prime coat of redoxide where necessary etc. complete in all floors as per drawing and direction of Engineer in charge.	sqm
76-350	Supplying and fitting fixing of window grills of normal ornamental design, made of mild steel flat bars of size 20mmx6mm with outer frame of 25mmx6mm F.I.bar, including necessary drilling, fabricating, welding with a prime coat of redoxide where necessary etc. complete in all floors as per drawing and direction of Engineer in charge.	sqm
76-360	Supplying and fitting fixing of window grills of ornamental design, made of mild steel flat bars of size 20mmx5mm with outer frame of 25mmx6mm F.I.bar, including necessary drilling, fabricating, welding with a prime coat of redoxide where necessary etc. complete in all floors as per drawing and direction of Engineer in charge.	sqm

ITEM DEFINITION REPORT

ItemCode	Item Description	Unit Meas.
76-370	Supplying, fitting and fixing of the catch hooks of approved quality.	each
76-370-10	150mm long.	each
76-370-20	250mm long.	each
76-380	Supplying, fitting and fixing of 230mm to 300mm long adjustable window stopper of F.I. bar (minimum size 20mmx4mm) of approved quality and as per direction of Engineer in charge.	each
76-390	Supplying and fitting fixing flat iron clamps 30mm wide, 250mm long and 6mm thick, embedded in wall with cement concrete (1:2:4) including fixing with door frames with necessary screws etc. complete in all floors as per direction of Engineer in charge.	each
76-400	Supplying, fitting and fixing of angle iron frame for door and window, with 30mmx30mmx6mm M.S. angles, including fitting and fixing with F.I.bar clamps 200mmx30mmx5mm duly embedded in cement concrete (1:3:6), necessary welding, finishing etc. complete, in all floors, as per drawing and direction of the Engineer in charge.	kg
76-410	Supplying, fitting and fixing of steel frame sliding door 2.44mx2.44m in size, with 50mmx50mmx10mm M.S. angle frame, 8mm thick M.S. plate for shutter, as per drawing, providing 3nos. M.S. FI bar 50mmx10mm, both ways, wheels on both lower and upper side, and runner at bottom and top, including locking arrangement etc. complete.	sqm
76-420	Manufacturing, supplying, fitting and fixing collapsible gate made of 20mmx6mmx3mm M.S. channel placed @ 110mm c/c vertically and connecting the same with each other with 20mmx3mm M.S. flat bar, scissors 525mm/600mm long provided in 3 rows including cutting the different M.S. members to required sizes, fabricating welding, rivetting with required size rivets, providing required size wheels, pulling handles on both sides, suitable locking arrangement and finally placing the same in position in between 2 nos. 50mmx56mmx6mm M.S. Tee rail made by welding 2 nos. 50mmx6mm M.S. flat bar fitted and fixed at top and bottom with R.C.C. lintel/roof slab, floors and side wall with required nos. 150mm to 225mm long 40mmx6mm M.S. flat bar clamps one end welded with the gate member and the other end bifurcated and embedded in C.C. (1:2:4) including cutting holes, with a prime coat of redoxide where necessary etc. all complete as per drawing and direction of Engineer in charge.	sqm
76-430	Supplying, fitting and fixing tower bolts of approved quality, with necessary screws etc. complete:	each
76-430-10	Brass tower bolts, 300 mm long and 19 mm dia.	each
76-430-20	Brass tower bolts, 225mm long and 13mm dia.	each
76-430-30	Brass tower bolts, 150mm long and 13mm dia.	each
76-430-40	Brass tower bolts, 100mm long and 10mm dia.	each

ITEM DEFINITION REPORT

ItemCode	Item Description	Unit Meas.
76-430-50	Iron tower bolts, 225mm long and 13mm dia.	each
76-430-60	Iron tower bolts, 150mm long and 10mm dia.	each
76-430-70	Iron tower bolts, 100mm long and 10mm dia.	each
76-440	Supplying, fitting and fixing door spring, 225mm long, of approved quality and as per direction of Engineer in charge:	each
76-440-10	brass made	each
76-440-20	steel made	each
76-450	Supplying, fitting and fixing of approved quality C.P. door handle.	each
76-450-10	300mm long and 25mm dia.	each
76-450-20	225mm long and 25mm dia.	each
76-450-30	150mm long and 19mm dia.	each
76-460	Supplying, fitting and fixing of the hinges with screws as per approved quality.	each
76-460-10	Iron made 100mm.	each
76-460-20	Iron made 75mm.	each
76-460-30	Brass made 100mm.	each
76-460-40	Brass made 75mm.	each
76-470	Supplying, fitting and fixing of the 225mm long hasp bolts of approved quality and as per direction of Engineer in charge.	each
76-470-10	Made of brass.	each
76-470-20	Made of C.P. steel.	each
76-480	Supplying, fitting and fixing of rolling shutter of 22 gauge G.I. sheet, with M.S. plate 76mmx6.40mm size, and 38mm dia G.I. pipe in top, providing 19mmx3mm flat bars, and 25mmx25mmx3mm M.S. angles, 10 gauge fan plate and best quality spring with a prime coat of redoxide where necessary etc. complete, as per direction and specification.	sqm
76-490	Supply,fitting and fixing of the new iron bolts(more than 150mm), nuts, iron cleats and fish plates, including forging,drilling etc. complete.	kg
76-500	Supplying, fitting and fixing lead sheet of any size in bearing (hinge or free), including cutting to desired shape and placing between top and bottom plate etc. complete as per direction of Engineer in charge.	kg

ITEM DEFINITION REPORT

ItemCode	Item Description	Unit Meas.
76-510	Supplying, fitting and fixing of M.S. bearing plate (hinge or free) of desired size including cutting to size, fabrication, welding of M.S. lug and M.S. anchor bar around periphery, providing hinge bar, and fixing in abutments/girders/bases etc. complete with supply of all materials as per drawing, specification and direction of Engineer in charge (excluding cost of M.S. bar).	kg
76-520	Cutting M.S. plate/sheet pile with Oxy-acetylene flame to desired shape and size and as per direction of Engineer in charge.	m
76-520-10	3mm thick plate.	m
76-520-20	6mm thick plate.	m
76-520-30	9mm thick plate.	m
76-520-40	12mm thick plate.	m
76-520-50	15mm thick plate.	m
76-520-60	18mm thick plate.	m
76-520-70	20mm thick plate.	m
76-520-80	25mm thick plate.	m
76-530	Supplying steel tender box made of 18 BWG M.S. steel sheet of size 450mmx600mmx900mm including necessary locking arrangements and two coats of spray paints over a coat of priming etc. complete as per direction of Engineer in charge.	each
76-550	Supplying and fitting fixing of fan hook with 16mm dia m.s.rod as per direction of Engineer in charge.	each
76-610	Removal of old rubber seal and supplying, fitting, fixing new P-type rubber seal in vertical lift gate/flap gate including making necessary holes, replacing all damaged nuts & bolts and clamp bars etc. complete including the cost of all materials as per direction of Engineer in charge.	m
76-610-10	Size : Width = 75mm, Thickness = 12mm and Bulb dia = 25mm.	m
76-610-20	Size : Width = 100mm, Thickness = 16mm and Bulb dia = 45mm.	m
76-630	Supply and fitting and fixing 23cm wide P.V.C water stops having minimum strength of 13.80 N/mm ² at 225% elongation and of approved quality in contraction and expansion joints with necessary arrangements for modification in shuttering and keeping the water stop in position etc. complete as per design, specification and direction of Engineer in charge.	m
76-630-10	3 bulb type.	m
76-630-20	Corrugated type.	m

ITEM DEFINITION REPORT

ItemCode	Item Description	Unit Meas.
76-640	Labour charge for fitting and fixing 23cm wide P.V.C water stops, in the contraction and expansion joints of hydraulic structures, with necessary modification of formworks, as per design, specification and direction of Engineer in charge.	m
76-640-10	3 bulb type.	m
76-640-20	Corrugated type.	m
76-710	Supply, fitting and fixing of approved quality Mortice lock with handle, necessary screws etc. complete including duplicate keys.	each
76-710-10	England/Germany made.	each
76-710-20	Japan made.	each
76-710-30	Korea made.	each
76-710-40	China/Taiwan made.	each
76-710-50	Bangladesh made.	each
76-720	Supply, fitting and fixing approved quality cylindrical mortice lock (round lock) with necessary srews etc. complete with supply of duplicate keys.	each
76-720-10	Both sides key (Japan).	each
76-720-20	Both sides key (Korea).	each
76-720-30	Both sides key (China/Taiwan).	each
76-720-40	Both sides key (Bangladesh).	each
76-720-50	One side key/ One side push (Japan).	each
76-720-60	One side key/ One side push (Korea).	each
76-720-70	One side key/ One side push (China/Taiwan).	each
76-720-80	One side key/ One side push (Bangladesh).	each
76-750	Providing and fitting fixing encased Rubber (Elastomeric) Bridge Bearing reinforced with steel plates under girders including cost of bearing and fitting charge etc. complete in all respect as per approved design, drawing, in conformity with BS-5400 having minimum tensile strength of 15.5 N/mm ² , minimum elongation at break 350% and maximum compression set at 35% and as per direction of Engineer in charge.	cm3
76-780	supplying and fitting, fixing dowel bar in expansion joints of hydraulic structures with 32 mm dia M.S.plain bar 2000 mm long, hooked in one end and painted at the other end for a length of 900 mm with 40 mm dia 100 mm long G.I./M.S. pipe closed at one end and filled with 30 mm thick compressible filler, including placing in position, binding with G.I. Wire etc. complete as per direction of Engineer in charge.	each

ITEM DEFINITION REPORT

ItemCode	Item Description	Unit Meas.
80 . Plumbing Work		
80-100	Supplying and sinking 40mm dia G.I. tubewell pipe including test boring and hiring of all necessary equipments with all necessary fittings as required etc. all complete including the cost of all materials as per direction of Engineer in charge.	m
80-100-10	Depth upto 60m.	m
80-100-20	Depth above 60m.	m
80-110	Supplying and sinking 40mm dia PVC tubewell pipe (B.S. 3505) including test boring and hiring of all necessary equipments with all necessary fittings as required etc. complete including the cost of all materials as per direction of Engineer in charge.	m
80-110-10	depth upto 60m.	m
80-110-20	depth above 60m.	m
80-120	Supplying, fitting and fixing 40mm dia brass/PVC strainer, 1.80m long including hiring necessary equipments and supply of all necessary fittings etc. complete including the cost of all materials as per direction of Engineer in charge.	each
80-120-10	Brass strainer.	each
80-120-20	PVC strainer.	each
80-140	Supplying, fitting and fixing pump No. 6 for 40mm dia tubewell, as per approved quality with all accessories etc. complete including the cost of all materials as per direction of Engineer in charge.	each
80-150	Labour charge for taking out and resinking of 40mm dia G.I. tubewell pipes upto required depth, including test boring and hire charge of the equipments with all necessary fittings as required etc. complete, as per direction of Engineer in charge.	m
80-150-10	Depth upto 60m.	m
80-150-20	Depth above 60m.	m
80-160	Labour charge for taking out 40mm dia tubewell pipes including cleaning the pipes and other fittings, as per direction of Engineer in charge.	m
80-180	Supplying and installation of ferrocement overhead tank, 1.2mx1.2mx1.2m size of 1800 litre capacity with standard manhole cover and ball valve manufactured in accordance with approved specification of HBR Institute including fitting and fixing inlet and outlet pipe, overflow pipe, plug and jam-nut including carriage, local handling, lifting, operating, testing etc. complete as per direction of Engineer in charge.	no

ITEM DEFINITION REPORT

ItemCode	Item Description	Unit Meas.
80-200	Supplying, fitting and fixing in position G.I. over head tank 1.20mx1.20mx1.20m size of 1800 litres capacity with 200mm dia C.I. manhole cover with locking arrangement and 25mm dia ball valve, including fitting and fixing inlet and outlet pipe, overflow pipe, plug and jam nut etc. complete with anticorrosive paint of approved quality and as per direction of Engineer in charge:	each
80-200-10	16 BWG, over head tank	each
80-200-20	18 BWG, over head tank	each
80-205	Supplying and installation of plastic overhead water tank including carriage and all accessories except preparation of base and cost of overflow pipe, of different capacity and size with cover and ball valve including fitting fixing inlet and outlet etc. complete as per direction of Engineer-in-charge.	
80-205-10	Capacity: 300 ltr	each
80-205-20	Capacity: 500 ltr	each
80-205-30	Capacity: 1000 ltr	each
80-210	Hoisting or taking down 1800 litre capacity G.I. over head tank, including fitting, fixing etc. complete.	each
80-230	Supplying, laying, fitting and fixing of different dia G.I. pipes with all special fittings, such as bends, elbows, sockets, tees, unions, jamnuts etc. including cutting foundation trenches upto required depth where necessary and filling the same with earth duly compacted, making holes in floors and walls and mending the damages, fixing in walls with holders and clips, including cutting threads, making necessary connection etc. all complete, and as per direction of Engineer in charge:	m
80-230-10	13mm dia G.I. pipe line.	m
80-230-20	19mm dia G.I. pipe line.	m
80-230-30	25mm dia G.I. pipe line.	m
80-230-40	40mm dia G.I. pipe line.	m
80-240	Extra rates for concealing G.I.pipes (13mm to25mm) in brickwall/ concrete by cutting wall, slab, lintel, beam etc. by any means carefully without damaging the structure and filling the grooves after laying of pipes with C.C.(1:2:4) etc. all complete in all floors as per direction of Engineer in charge.	m
80-260	Supplying, fitting and fixing of the different dia G.I. water distribution pipe line, with all special fittings such as bends, elbows, sockets, reducing sockets, tees, unions etc including cutting trench up to an average depth of 0.90m, maintaining proper level, cutting pipes where necessary, making threads etc. all complete, as per direction of Engineer in charge:	m
80-260-10	40mm dia G.I. pipe line	m

ITEM DEFINITION REPORT

ItemCode	Item Description	Unit Meas.
80-260-20	50mm dia G.I. pipe line	m
80-260-30	75mm dia G.I. pipe line	m
80-270	Supplying, fitting and fixing CI/PVC. pipe, with necessary bends, tees, elbows, clamps etc. and oter necessary fittings for all types of works as per direction of Engineer in charge:	m
80-270-10	50mm dia C.I. pipe.	m
80-270-20	100mm dia C.I. pipe.	m
80-270-30	100mm dia PVC pipe	m
80-280	Supplying, fitting and fixing of 13mm dia lead plastic pipes, 400mm long, with 13mm dia brass tail and nut, including plumbing joints etc. complete as per direction of Engineer in charge.	each
80-290	Painting of 13mm dia to 40mm dia G.I. pipes, with approved paint over a coat of priming.	m
80-300	Supplying, fitting and fixing of C.P.Bib cock of approved quality as per direction of Engineer in charge.	each
80-300-10	13mm dia.	each
80-300-20	19mm dia.	each
80-310	Supplying, fitting and fixing of C.P. pillar cock of approved quality:	each
80-310-10	13mm dia.	each
80-310-20	19mm dia.	each
80-320	Supplying, fitting and fixing of brass bib cock of approved quality:	each
80-320-10	13mm dia.	each
80-320-20	19mm dia.	each
80-330	Supplying, fitting and fixing of check valves of approved quality.	each
80-330-10	13mm dia.	each
80-330-20	19mm dia.	each
80-330-30	25mm dia.	each
80-330-40	40mm dia.	each
80-330-50	50mm dia.	each
80-330-60	75mm dia.	each
80-330-70	100mm dia.	each

ITEM DEFINITION REPORT

ItemCode	Item Description	Unit Meas.
80-340	Supplying, fitting and fixing of gate valve of approved quality:	each
80-340-10	13mm dia	each
80-340-20	19mm dia	each
80-340-30	25mm dia	each
80-340-40	40mm dia	each
80-340-50	50mm dia	each
80-340-60	75mm dia	each
80-340-70	100mm dia	each
80-350	Supplying, fitting and fixing of controlling valve stop cock of approved quality as per direction of Engineer in charge.	each
80-350-10	13mm dia brass	each
80-350-20	19mm dia brass	each
80-350-30	13mm dia CP	each
80-350-40	19mm dia CP	each
80-370	Supplying, fitting and fixing of the G.I. plug:	each
80-370-10	40mm dia	each
80-370-20	25mm dia	each
80-370-30	19mm dia	each
80-370-40	13mm dia	each
80-380	Supplying, fitting and fixing of ball cock of approved quality:	each
80-380-10	25mm dia.	each
80-380-20	19mm dia.	each
80-380-30	13mm dia.	each
80-390	Supplying, fitting and fixing of plastic coupling:	each
80-390-10	25mm dia	each
80-390-20	19mm dia	each
80-390-30	13mm dia	each

ITEM DEFINITION REPORT

ItemCode	Item Description	Unit Meas.
80-400	Renewing of C.P./brass bib cock of approved quality, including fitting, fixing and removing the old one with supply of all materials as per direction of Engineer in charge.	each
80-400-10	13mm dia brass.	each
80-400-20	13mm dia C.P.	each
80-410	Renewing of brass controlling valve stop cock/gate valve of approved quality, including fitting, fixing and removing the old one with supply of all materials as per direction of Engineer in charge.	each
80-410-10	40mm dia	each
80-410-20	25mm dia	each
80-410-30	19mm dia	each
80-410-40	13mm dia	each
80-420	Renewing of C.P. pillar cock of approved quality, including fitting, fixing and removing the old one with supply of all materials as direction of Engineer in chargr.	each
80-420-10	19mm dia	each
80-420-20	13mm dia	each
80-430	Renewing of C.P. controlling valve/stop cock of approved quality, including fitting, fixing and removing the old one with supply of all materials as per direction of Engineer in charge.	each
80-430-10	19mm dia.	each
80-430-20	13mm dia.	each
80-470	Making connection with the water main, including earth cutting, filling up trenches properly and mending all damages etc. complete as per direction of Engineer in charge.	each
80-480	Supplying, fitting and fixing of the 100mm dia gratings as per direction of Engineer in charge.	each
80-480-10	H.C.I. gratings	each
80-480-20	C.P. or aluminium gratings	each
80-510	Labour charge for fitting and fixing rain water pipes, with all fittings, such as sockets, bends, elbows, tees etc. complete as per direction of Engineer in charge.	m
80-510-10	75mm dia PVC pipe.	m
80-510-20	100mm dia PVC pipe.	m

ITEM DEFINITION REPORT

ItemCode	Item Description	Unit Meas.
80-510-30	100mm dia HCI pipe.	m
80-520	Labour charge for fitting and fixing 50mm dia H.C.I. gas pipe, including fitting fixing bends, door bends, junctions, cowels etc. all complete as per direction of Engineer in charge.	m
80-550	Supplying, fitting and fixing of 13.64 litres low level porcelain flushing cistern set of approved quality including all fittings complete, as per direction of Engineer in charge.	each
80-580	Supplying, fitting and fixing 13.64 litres heavy type C.I.high level cistern, including necessary PVC flush pipe and all fittings i.e. lead pipe, bend, ball cock etc. complete, as per direction of Engineer in charge:	each
80-590	Taking out flushing cistern and refitting, including scrapping out inside rust, colouring both inside and out side with approved colour paint and proper adjustment of inside fittings etc. complete as per direction of Engineer in charge.	each
80-600	Supplying, fitting and fixing of cast iron enamelled porcelain bath tub 1.68m long, with two 19mm dia hot/cold E.C.C.I. pillar taps, 40mm dia C.I. overflow, 38mm C.P. waste chain and plug, including making holes to walls and floors, mending damages etc. complete, as per direction of Engineer in charge.	set
80-620	Supplying and fitting fixing "BISF STANDARD" white glazed vitreous Wash Hand Basin (685mmx460mmx235mm, size) including fitting, fixing the same in position with heavy type C.I. Brackets, 30mm dia PVC waste water pipe with brass coupling, 13mm dia plastic connection pipe with brass coupling, 13mm dia brass Stop Cock, 13mm C.P. Pillar Cock, 30mm dia C.P. Basin Waste with chain plug including making holes in walls and floors and fitting with wooden blocks, screws and mending good the damages etc complete as per direction of Engineer in Charge.	each
80-620-10	White	each
80-620-20	Coloured	each
80-630	Labour charge for fitting and fixing of wash hand basin with single or double tab holes, including all fittings, cutting holes in walls, fixing brackets, mending the damages etc complete as per direction of Engineer in charge.	each
80-650	Supplying, fitting and fixing of bath room mirror with C.P. screws and hard board backing complete, as per direction of Engineer in charge:	each
80-650-10	0.45m x 0.60m size, Bangladesh.	each
80-650-20	0.45m x 0.35m size, Bangladesh.	each
80-650-30	0.45m X 0.60m size, Japan/Belgium.	each
80-650-40	0.45m X 0.35m size, Japan/Belgium.	each

ITEM DEFINITION REPORT

ItemCode	Item Description	Unit Meas.
80-660	Supplying, fitting and fixing of approved quality C.P. towel rail, with all necessary accessories etc. complete, as per direction of Engineer in charge:	each
80-660-10	0.75m long and 25mm square/round	each
80-660-20	0.75m long and 19mm dia round/square	each
80-660-30	0.60m long and 19mm round/square	each
80-670	Supplying, fitting and fixing of the approved quality bath room fittings, with all necessary accessories etc. complete, as per direction of Engineer in charge.	each
80-670-10	C.P. soap dish.	each
80-670-20	C.P. coat hook.	each
80-670-30	C.P. tumbler holder.	each
80-670-40	C.P. toilet paper holder	each
80-670-50	C.P. tooth brush holder.	each
80-680	Supplying, fitting and fixing of C.P. shower set with 130mm dia, 125mm face C.P. shower, 13mm dia C.P. contolling valve, and 13mm dia C.P. bib cock etc. complete, as per dsierction of Engineer in charge.	each
80-690	Supplying, fitting and fixing of the approved quality glass shelf, 6mm thick with C.P. bracket and guard rail, including all necessary accessories etc. complete, as per direction of Engineer in charge:	each
80-690-10	610mm x 130mm.	each
80-690-20	450mm x 130mm.	each
80-700	Supplying, fitting and fixing of BISF STANDARD porcelain kitchen sink, fitted and fixed with heavy type C.I.brackets, 13 mm dia C.P. bib cock, 40 mm dia C.P. waste & chain plug, 38 mm dia PVC waste pipe with brass coupling (750mm length), including making holes in walls and floors and mending the damages etc complete as per direction of Engineer in charge.	set
80-700-10	Size: 515mm x 430mm x 275mm; white	each
80-700-20	Size: 515mm x 430mm x 275mm; coloured	each
80-700-30	Size: 625mm x 490mm x 225mm; with sink tray, white	each
80-700-40	Size: 625mm x 490mm x 225mm; with sink tray, coloured	each
80-710	Supplying, fitting and fixing of the stainless steel kitchen sink of 1000mmx510mmx460mm size, with 13mm dia C.P.bib cock, 40mm dia C.P. waste & chain plug, 40mm dia PVC waste pipe (750mm length), heavy type C.P. brackets, including making holes in walls and floors and mending the damages etc. complete as per direction of Engineer in charge.	each

ITEM DEFINITION REPORT

ItemCode	Item Description	Unit Meas.
80-720	Supplying, fitting and fixing, Bangladesh pattern 'BISF STANDARD' long pan with white vitreous china syhone and preparing the base of pan with cement concrete and wirenet or m.s.rods if necessary in floors including making holes in walls and floors wherever required and mending good the the damages and supplying 13.60 litres capacity C.I. cistern with all fittings and fitting, fixing the same in position with C.I. Brackets including supply of best quality 30mm dia PVC flush pipe with brass coupling, 13mm brass stop cock, 13mm dia ball cock and pulling chain etc. all complete as per direction of Engineer in charge:	pset
80-720-10	Size: 555mm x 290mm x 270mm, simple type, white.	pset
80-720-20	Size: 555mm x 290mm x 270mm, simple type, coloured.	pset
80-720-30	Size: 510mm x 280mm x 260mm, simple type, white.	pset
80-720-40	Size: 510mm x 280mm x 260mm, simple type, coloured.	pset
80-720-50	Size: 590mm x 460mm x 290mm, Orissa Type, white.	pset
80-720-60	Size: 590mm x 460mm x 290mm, Orissa Type, coloured.	pset
80-740	Supplying 'BISF STANDARD' quality glazed porcelain foot rest (265mmx130mmx40mm size) for eastern type pan, including fitting and fixing in position etc. complete as per direction of Engineer in charge.	pair
80-750	Supplying, fitting and fixing European type glazed pocelain commode 'P' or 'S' type 'BISF STANDARD' (580mmX345mmx410mm) with lowdown white vitreous china cistern including all internal fittings with ebonite (heavy type) plastic seat cover, 13mm dia approved quality C.P. stop cock, 13mm dia plastic connection pipe with brass coupling and preparing the base with cement concrete and with wire nets or rods, if necessary, in all floors including making necessary holes wherever required and mending good the damages and fitting fixing complete with all necessary fittings and connection as per direction of Engineer in charge.	each
80-750-10	White.	set
80-750-20	Coloured.	set
80-770	Supplying, fitting and fixing 'BISF STANDARD' European type glazed vitreous standing urinal (310mmx260mmx490mm) including fitting fixing the same in position after making holes in walls and floors, providing 30mm dia plastic waste pipe with brass coupling, 13mm dia plastic connection pipe with brass coupling, 13mm dia C.P.Stop cock including mending good the damages etc all complete as per direction of Engineer in charge:	set
80-770-10	White	set
80-770-20	Coloured	set

ITEM DEFINITION REPORT

ItemCode	Item Description	Unit Meas.
80-780	Supplying,fitting and fixing 'BISF STANDARD' glazed vitreous china squatting or flat urinals (610mm x 370mm x 85mm) with flushing inlet fitted in cement concrete with cast iron painted body, one gallon automatic flushing cistern in each group etc.with 13mm dia brass controlling valve, 30mm dia PVC flush pipe with brass coupling, 13mm dia plastic connection pipe with brass coupling including mending good the damages etc. all complete as per direction of Engineer in charge:	set
80-780-10	White.	set
80-780-20	Coloured.	set
80-800	Fitting, fixing 150mm dia R.C.C. pipe (excluding the cost of pipe & sockets) including laying in position over 75mm thick, 150mm wide cement concrete (1:3:6) at base including 250mm width single brick flat soling and gasket with cement mortar joints, cutting and filling trenches upto required depth etc. all complete in all respect as per plan and direction of Engineer in charge.	m
80-810	Supplying, fitting and fixing 100mm dia C.I. traps (syphone trap or P-trap) including making holes in walls and floors and mending good the damages etc. all complete as per direction of Engineer in charge.	each
80-820	Supplying, fitting and fixing of H.C.I. pipe with all fittings such as bend (door and plain), Tees, sockets, junction (door and plain) both double and single, cowels, antisiphones etc. with wood pins, with nails and washer, making holes in walls and floors, and mending good the damages, chaulking joints with gasket and pig lead etc. complete as per direction of Engineer in charge.	m
80-820-10	100mm dia soil pipe.	m
80-820-20	50mm dia ventilation pipe.	m
80-830	Supplying, fitting, fixing 50mm dia PVC best quality (BS 3505) ventilation pipe with all fittings such as plain bends, tees, cowels etc. including gasket with high class solution and making holes in walls and mending good the damages etc. all complete as per direction of Engineer in charge.	m
80-840	Labour charge for fitting and fixing of H.C.I. soil pipe with all fittings such as bends, junction, cowels, clamps etc. including cutting holes in walls and floors, fixing blocks and mending good the damages etc. complete as per direction of Engineer in charge.	m
80-860	Labour charge for fitting and fixing 100mm dia R.C.C.or C.I. or S.W. drainage pipe, including laying in position, cutting trenches, chaulking out joints, with cement, gaskets and materials and filling up the tenches as per specification and direction of Engineer in charge.	m
80-870	Labour charge for fitting fixing water closet with high or low level flushing cistern with all necessary fittings including making holes in walls and floors, fixing with wire nets if necessary and mending good the damages etc complete, as per direction of Engineer in charge.	each
80-870-10	western styled water closet.	each

ITEM DEFINITION REPORT

ItemCode	Item Description	Unit Meas.
80-870-20	eastern and orissa type water closet.	each
80-880	Labour charge for fitting and fixing of the kitchen sink with all fittings including cutting holes in walls and mending good the damages etc. complete as per direction of Engineer in charge.	each
80-890	Construction of masonry inspection pits, 0.60mx0.60m inside measurement, with 250mm thick brick work (4:1), 100mm thick R.C.C. top slab (4:2:1) with 1% reinforcement, 450mm dia water sealed C.I.M.H. cover, including necessary earth work, one brick flat soling and 75mm thick 1:3:6 base concrete for making invert channel, complete with 13mm thick 2:1 cement plaster and neat cement finishing etc. complete upto a depth of 0.75m, as per direction of Engineer in charge.	each
80-900	Construction of septic tanks of different sizes with brick work (6:1), as per approved plan over a brick flat soling and 150mm cement concrete flooring (4:2:1) and with 125mm thick brick walls in partition , 20mm thick cement plaster on both sides with neat cement finishing and 25mm thick patent stone flooring with neat cement finishing, including supplying, fitting and fixing of two R.C.C tees and providing 2 numbers of C.I.M.H cover with 100mm R.C.C. slab (4:2:1) with minimum 1% reinforcement , shuttering, fabrication, casting and curing etc. complete upto any depth, including shoring, bailing out water and the cost of materials, and incidental charges etc. complete, as per design and direction of Engineer in charge (as per P.W.D drawings).	each
80-900-10	for 50 users.	each
80-900-20	for 30 users.	each
80-900-30	for 20 users.	each
80-900-40	for 10 users.	each
80-910	Construction of soak well of different sizes, with 250mm solid brick work and 250mm honey comb brick work in cement mortar (6:1) as per design, over R.C.C. well curve (4:2:1), with 1.50 % reinforcement up to the desired depth, as per drawing with 100mm thick R.C.C. cover slab (4:2:1), with 1% reinforcement, including supplying, fitting and fixing of 460mm C.I. manhole cover, filling the well up to the required depth, with graded khoa and sand, including supplying and fabricating M.S. rod, with cost of all materials etc. complete, as per drawing, design and direction of Engineer in charge (as per P.W.D. drawings):	each
80-910-10	for 50 users.	each
80-910-20	for 30 users.	each
80-910-30	for 20 users	each
80-910-40	for 10 users	each

ITEM DEFINITION REPORT

ItemCode	Item Description	Unit Meas.
80-920	Supplying, fitting and fixing of the C.I. inspection pit covers of 40mm thick and 460mm. dia, heavy type, water sealed set etc. complete, as per direction of Engineer in charge.	each
80-930	Labour charge for removing of silt, from soak well, including dewatering, taking out and refitting the cover etc complete as per direction of Engineer in charge.	each
80-940	Removing of sludge from inside of septic tank, cleaning, washing and repairing as necessary and filling with water as per direction of Engineer in charge.	cum

ITEM DEFINITION REPORT

ItemCode	Item Description	Unit Meas.
84 . Electrical Work		
84-100	Distribution wiring for light and fan points in conformity with IEE regulations in buildings, with twin core 2x1.5mm ² flat PVC insulated and sheathed wire on standard Ctg.T.W.batten 12mm thick, complete with circuit wiring, 5 Amps tumbler switch, ceiling rose, round block etc as required complete as per sample approved and direction of Engineer in charge in looping system at the switch board including supply of all materials.	point
84-100-10	Light point (Eastern cable with 16SWG ECC wire type BYFYE)	point
84-100-20	Fan point (Eastern cable with 16SWG ECC wire, type BYFYE)	point
84-100-30	2-pin 5 amps socket outlet with control switch on switch board (Eastern cable with 16SWG ECC wire, type BYFYE)	point
84-100-40	Call bell point with control switch on switch board (Eastern cable with 16SWG ECC wire, type BYFYE)	point
84-100-50	Light point (with minimum 16SWG ECC wire Jamuna/ Sunshine/ BRB or any approved wire, type BYM).	point
84-100-60	Fan point (with minimum 16SWG ECC wire Jamuna/ Sunshine/ BRB/ or any approved wire type BYM).	point
84-100-70	2-pin 5amps socket outlet with control switch on switch board (with 16SWG ECC wire Jamuna/ Sunshine/ BRB or any approved wire, type BYM).	point
84-100-80	Call bell point with control switch on switch board (with 16SWG ECC wire Jamuna/ Sunshine/ BRB or any approved wire, type BYM).	point
84-110	Surface conduit distribution wiring for light and fan points in conformity with IEE regulations in buildings, with single core 1x1.5mm ² PVC insulated and sheathed wire with 16SWG ECC through PVC pipe of minimum 26.50mm outer dia having wall thickness of minimum 1.50mm complete with 5amps tumbler switch, ceiling rose etc complete as per sample approved and direction of Engineer in charge in looping system at the switch board including supply of all materials.	point
84-110-10	Light point (wire type BYM of Eastern cable)	point
84-110-20	Fan point (wire type BYM of Eastern cable)	point
84-110-30	2-pin 5amps socket outlet in switch board with control switch (wire type BYM of Eastern cable)	point
84-110-40	Call bell point with control switch on switch board (wire type BYM of eastern cable)	point

ITEM DEFINITION REPORT

ItemCode	Item Description	Unit Meas.
84-120	Concealed conduit distribution wiring for light and fan points in conformity with IEE regulations in buildings, with single core 1x1.5mm ² PVC insulated and sheathed wire with 16SWG ECC through PVC pipe of 26.5mm outer dia having wall thickness of minimum 1.5mm complete with inspection box, 5amps piano type switch, ceiling rose, 3mm thick perspex sheet cover in switch board etc complete as per sample approved and direction of Engineer in charge in looping system at the switch board including supply of all materials and necessary cutting of wall/ floor and subsequent mending good of the damages etc. complete.	point
84-120-10	Light point (wire type BYM of Eastern cable)	point
84-120-20	Fan point (wire type BYM of Eastern cable)	point
84-120-30	2-pin 5 amps socket outlet with control switch (wire type BYM of Eastern cable)	point
84-120-40	Call bell point (wire type BYM of Eastern cable)	point
84-120-50	Light point (Jamuna/ Sunshine/ BRB or any approved wire, type BYM)	point
84-120-60	Fan point (Jamuna/ Sunshine/ BRB or any approved wire, type BYM)	point
84-120-70	2-pin 5amps socket outlet with control switch on switch board (Jamuna/ Sunshine/ BRB or any approved wire, type BYM)	point
84-120-80	Call bell point with control switch on switch board (Jamuna/ Sunshine/ BRB or any approved wire, type BYM)	point
84-130	Surface batten wiring with the undermentioned size of twin core PVC insulated and sheathed wire on 12mm thick Ctg.T.W.batten with ECC flat cable in conformity with IEE regulations in buildings complete as required etc as per sample approved and direction of Engineer in charge including supply of all materials.	m
84-130-10	1-2x1.5mm ² PVC insulated and sheathed wire (BYFYE of Eastern cable)	m
84-130-20	1-2x1.5mm ² PVC insulated and sheathed wire (Sunshine/ Jamuna/ BRB or any approved cable, type BYFYE)	m
84-130-30	1-2x2.5mm ² PVC insulated and sheathed wire (BYFYE of Eastern cable)	m
84-130-40	1-2x2.5mm ² PVC insulated and sheathed wire (Sunshine/ Jamuna/ BRB or any approved cable, type BYFYE)	m
84-130-50	1-2x4.0mm ² PVC insulated and sheathed wire (BYFYE of Eastern cable)	m
84-130-60	1-2x4.0 mm ² PVC insulated and sheathed wire (Sunshine/ Jamuna/BRB or any approved cable, type BYFYE)	m
84-130-70	1-2x6.0mm ² PVC insulated and sheathed wire (BYFYE of Eastern cable)	m
84-130-80	1-2x6.0mm ² PVC insulated and sheathed wire (Sunshine/ Jamuna/ BRB or any approved cable, type BYFYE)	m

ITEM DEFINITION REPORT

ItemCode	Item Description	Unit Meas.
84-150	Surface conduit wiring with the undermentioned size of single core PVC insulated and sheathed wire through PVC pipe of minimum 26.5mm outer dia having minimum wall thickness of 1.5mm with ECC in conformity with IEE regulations in buildings complete as required etc as per sample approved and direction of Engineer in charge including supply of all materials.	m
84-150-05	2-1x1.5mm ² BYM with 14SWG.HDBC ECC wire (BYM of Eastern Cable)	m
84-150-10	2-1x1.5mm ² BYM with 14SWG.HDBC ECC wire (Sunshine/ Jamuna/ BRB or any approved cable)	m
84-150-15	2-1x2.5mm ² BYM with 14SWG.HDBC ECC wire (BYM of Eastern Cable)	m
84-150-20	2-1x2.5mm ² BYM with 14SWG.HDBC ECC wire (Sunshine/ Jamuna/ BRB or any approved cable)	m
84-150-25	2-1x4.0mm ² BYM with 14SWG.HDBC ECC wire (BYM of Eastern Cable)	m
84-150-30	2-1x4.0mm ² BYM with 14SWG.HDBC ECC wire (Sunshine/ Jamuna/ BRB or any approved cable)	m
84-150-35	2-1x6.0mm ² BYM with 14SWG.HDBC ECC wire (BYM of Eastern Cable)	m
84-150-40	2-1x6.0mm ² BYM with 14SWG.HDBC ECC wire (Sunshine/ Jamuna/ BRB or any approved cable)	m
84-150-45	2-1x10.0mm ² BYM with 14SWG.HDBC ECC wire (BYM of Eastern Cable)	m
84-150-60	2-1x16.0mm ² BYM with 14SWG.HDBC ECC wire (Sunshine/ Jamuna/ BRB or any approved cable)	m
84-160	Surface conduit wiring with the undermentioned size of 3-core PVC insulated and sheathed wire through PVC pipe of minimum 26.5mm outer dia having minimum wall thickness of 1.5mm with ECC in conformity with IEE regulations in buildings complete as required etc as per sample approved and direction of Engineer in charge including supply of all materials.	m
84-160-05	1-3x1.5mm ² BYM with 14SWG.HDBC ECC wire (BYM of Eastern Cable)	m
84-160-10	1-3x1.50mm ² BYM with 14SWG.HDBC ECC wire (Sunshine/ BRB/ Jamuna or any approved cable)	m
84-160-15	1-3x2.5mm ² BYM with 14SWG.HDBC ECC wire (BYM of Eastern Cable)	m
84-160-20	1-3x2.50mm ² BYM with 14SWG.HDBC ECC wire (Sunshine/ Jmuna/ BRB or any approved cable)	m
84-160-25	1-3x4.0mm ² BYM with 14SWG.HDBC ECC wire (BYM of Eastern Cable)	m
84-160-30	1-3x4.0mm ² BYM with 14SWG.HDBC ECC wire (Sunshine/ BRB/ Jamuna or any approved cable)	m
84-160-35	1-3x6.0mm ² BYM with 14SWG.HDBC ECC wire (BYM of Eastern Cable)	m

ITEM DEFINITION REPORT

ItemCode	Item Description	Unit Meas.
84-160-40	1-3x6.0mm ² BYM with 14SWG.HDBC ECC wire (Sunshine/ Jamuna/ BRB or any approved cable)	m
84-160-45	1-3x10.0mm ² BYM with 14SWG.HDBC ECC wire (BYM of Eastern Cable)	m
84-160-50	1-3x10.0mm ² BYM with 14SWG.HDBC ECC wire (Sunshine/ Jamuna/ BRB or any approved cable)	m
84-190	Concealed conduit wiring with the undermentioned size of single core PVC insulated and sheathed wire through PVC pipe of minimum 26.5mm outer dia having minimum wall thickness of 1.5mm with ECC in conformity with IEE regulations in buildings complete as required etc as per sample approved and direction of Engineer in charge including supply of all materials and necessary cutting of wall/ floor and subsequent mending good of the damages etc. complete.	m
84-190-05	2-1x1.50mm ² BYM with 14SWG.HDBC ECC wire (BYM of Eastern Cable)	m
84-190-10	2-1x1.5mm ² BYM with 16SWG.HDBC ECC wire (Sunshine/ Jamuna/ BRB or any approved cable)	m
84-190-15	2-1x2.50mm ² BYM with 14SWG.HDBC ECC wire (BYM of Eastern Cable)	m
84-190-20	2-1x2.5mm ² BYM with 16SWG.HDBC ECC wire (Sunshine/ Jamuna/ BRB or any approved cable)	m
84-190-25	2-1x4.0mm ² BYM with 14SWG.HDBC ECC wire (BYM of Eastern Cable)	m
84-190-30	2-1x4.0mm ² BYM with 14SWG.HDBC ECC wire (Sunshine/ Jamuna/ BRB or any approved cable)	m
84-190-35	2-1x6.0mm ² BYM with 14SWG.HDBC ECC wire (BYM of Eastern Cable)	m
84-190-40	2-1x6.0mm ² BYM with 14SWG.HDBC ECC wire (Sunshine/ Jamuna/ BRB or any approved cable)	m
84-190-45	2-1x10.0mm ² BYM with 14SWG.HDBC ECC wire (BYM of Eastern Cable)	m
84-190-50	2-1x10.0mm ² BYM with 14SWG.HDBC ECC wire (Sunshine/ Jamuna/ BRB or any approved cable)	m
84-210	Wiring with the following size of PVC insulated and sheathed wire (type NYY single/ twin core of Eastern cable) through 19mm dia G.I.Pipe by laying the pipe in underground trench of minimum 30cm width and 75cm depth, including cutting trench and refilling the trench with earth duly rammed through G.I.Pipe in concealed system by cutting wall/ floor/ ceiling etc and consequent mending good the damages with ECC in conformity with IEE regulations in buildings complete as required etc as per sample approved and direction of Engineer in charge including supply of all materials.	m
84-210-10	2-1x1.5mm ² with No.14SWG.HDBC ECC wire (NYY of Eastern cable)	m
84-210-20	2-1x2.5mm ² with No.14SWG.HDBC ECC wire (NYY of Eastern cable)	m

ITEM DEFINITION REPORT

ItemCode	Item Description	Unit Meas.
84-210-30	2-1x4.0mm ² with No.14SWG.HDBC ECC wire (NYY of Eastern cable)	m
84-210-40	2-1x6.0mm ² with No.14SWG.HDBC ECC wire (NYY of Eastern cable)	m
84-210-50	2-1x10.0mm ² with No.14SWG.HDBC ECC wire (NYY of Eastern cable)	m
84-210-60	2-1x16.0mm ² with No.14SWG.HDBC ECC wire (NYY of Eastern cable)	m
84-220	Wiring with the following size of PVC insulated and sheathed wire (type NYY single/ three core of Eastern cable) through 19mm dia G.I.Pipe by laying the pipe in underground trench of minimum 30cm width and 75cm depth, including cutting trench and refilling the trench with earth duly rammed through G.I.Pipe in concealed system by cutting wall/ floor/ ceiling etc and consequent mending good the damages with ECC in conformity with IEE regulations in buildings complete as required etc as per sample approved and direction of Engineer in charge including supply of all materials.	m
84-220-05	1-3x1.5mm ² with No.14SWG.HDBC ECC wire (NYY of Eastern Cable)	m
84-220-10	3-1x1.5mm ² with No.14SWG.HDBC ECC wire (NYY of Eastern cable)	m
84-220-15	1-3x2.5mm ² with No.14SWG.HDBC ECC wire (NYY of Eastern Cable)	m
84-220-20	3-1x2.5mm ² with No.14SWG.HDBC ECC wire (NYY of Eastern cable)	m
84-220-25	1-3x4.0mm ² with No.14SWG.HDBC ECC wire (NYY of Eastern Cable)	m
84-220-30	3-1x4.0mm ² with No.14SWG.HDBC ECC wire (NYY of Eastern cable)	m
84-220-35	1-3x6.0mm ² with No.14SWG.HDBC ECC wire (NYY of Eastern Cable)	m
84-220-40	3-1x6.0mm ² with No.14SWG.HDBC ECC wire (NYY of Eastern cable)	m
84-220-45	1-3x10.0mm ² with No.14SWG.HDBC ECC wire (NYY of Eastern Cable)	m
84-220-50	3-1x10.0mm ² with No.14SWG.HDBC ECC wire (NYY of Eastern cable)	m
84-290	Supplying fitting fixing and connecting sub busbar TPN, assembled in 16SWG metal board with hinge type cover etc in conformity with IEE regulations in buildings complete as required, as per sample approved and direction of Engineer in charge including supply of all materials.	each
84-290-10	200A, 500V, TPN, (minimum cross sectional area of busbar=150mm ² and minimum lenth=910mm)	each
84-290-20	100A, 500V, TPN, (minimum cross sectional area of busbar=70mm ² and minimum lenth=690mm)	each
84-290-30	60A, 500V, TPN, (minimum cross sectional area of busbar=60mm ² and minimum lenth=495mm)	each
84-290-40	30A, 500V, TPN, (minimum cross sectional area of busbar=45mm ² and minimum lenth=340mm)	each

ITEM DEFINITION REPORT

ItemCode	Item Description	Unit Meas.
84-300	Supplying, fitting, fixing and connecting of the iron clad main switch, fuse unit on the surface of the wall, with sealed and interlocked switch handle, on angle iron, as per specification:	each
84-300-10	main switch, 200 A, 500 V, TPN	each
84-300-20	main switch, 100 A, 500 V, TPN	each
84-300-30	main switch, 60 A, 500 V, TPN	each
84-300-40	main switch, 30 A, 500 V, TPN	each
84-300-50	main switch, 15 A, 500 V, TPN	each
84-300-60	main switch, 15 A, 250 V, SPN	each
84-300-70	main switch, 30 A, 250 V, SPN	each
84-300-80	main switch, 60 A, 250 V, SPN	each
84-310	Supplying, fitting, fixing and connecting of the iron clad single phase branch distribution fuse board (BDB), assembled in a 16SWG metal enclosure including providing 15amps cutout with rewirable type fuse link carrier and one common copper conductor for neutral connection etc complete, on the surface of the wall as per direction of Engineer in charge:	each
84-310-05	15 A, 250 V, 2 way BDB	each
84-310-10	15 A, 250 V, 3 way BDB	each
84-310-15	15 A, 250 V, 4 way BDB	each
84-310-20	15 A, 250 V, 6 way BDB	each
84-310-25	15 A, 250 V, 8 way BDB	each
84-310-30	15 A, 250 V, 12 way BDB	each
84-310-35	30 A, 250 V, 3 way BDB	each
84-310-40	30 A, 250 V, 4 way BDB	each
84-310-45	30 A, 250 V, 6 way BDB	each
84-310-50	30 A, 250 V, 8 way BDB	each
84-320	Supplying, fitting, fixing and connecting of iron clad single phase branch distribution fuse board (BDB), assembled in 16SWG metal enclosure including providing 15amps cutout with rewirable type fuse link carrier and one common copper bar for neutral wire connection etc complete, concealed in the wall, as per direction of the Engineer in charge.	each
84-320-05	15A, 250V, 2-Way	each
84-320-10	15A, 250V, 3-Way	each

ITEM DEFINITION REPORT

ItemCode	Item Description	Unit Meas.
84-320-15	15A, 250V, 4-Way	each
84-320-20	15A, 250V, 6-Way	each
84-320-25	15A, 250V, 8-Way	each
84-320-30	15A, 250V, 12-Way	each
84-320-35	30A, 250V, 3-Way	each
84-320-40	30A, 250V, 4-Way	each
84-320-45	30A, 250V, 6-Way	each
84-320-50	30A, 250V, 8-Way	each
84-330	Supplying, fitting and fixing of wooden (Ctg.T.W) switch or junction board, on the surface of the wall, of different sizes, including fixing with wooden blocks or rowel plug, nails screws etc complete as required, as per sample approved and direction of Engineer in charge including supply of all materials.	each
84-330-10	size; 250mmx300mm	each
84-330-20	size; 200mmx300mm	each
84-330-30	size; 200mmx250mm	each
84-330-40	size; 180mmx130mm	each
84-330-50	size; 150mmx100mm	each
84-330-60	size; 80mmx80mm	each
84-330-70	size; 80mm round	each
84-330-80	size; 400mmx360mm	each
84-340	Supplying, fitting and fixing of steel switch board, inspection box or junction board, made of 16SWG sheet steel with perspex sheet cover of different sizes, concealed in the wall, including cutting holes in walls and mending good the consequent damages, complete as required, as per sample approved and direction of Engineer in charge including supply of all materials.	each
84-340-05	size; 400mmx360mm	each
84-340-10	size; 250mmx300mm	each
84-340-15	size; 200mmx360mm	each
84-340-20	size; 200mmx250mm	each
84-340-25	size; 180mmx130mm	each
84-340-30	size; 100mmx150mm	each

ITEM DEFINITION REPORT

ItemCode	Item Description	Unit Meas.
84-340-35	size; 80 mmx 80 mm	each
84-340-40	size; 80mm round	each
84-340-45	size; 400mmx300mm	each
84-340-50	size; 300mmx200mm	each
84-340-55	size; 200mmx150mm	each
84-340-60	size; 400mmx250mm	each
84-340-65	size; 400mmx400mm	each
84-340-70	size; 460mmx250mm	each
84-340-75	size; 760mmx810mm, with cover	each
84-340-80	size; 530mmx380mm, with cover	each
84-360	Supplying, fitting and fixing of 25mmthick (finished) wooden main switch board box, made of gamari or silkarai wood, of different sizes, fitted in wall, including fixing 4nos of iron angles of size 9mmx38mmx38mm, 460mm long, including cutting holes in walls and mending good the consequent damages with iron hinges, clamps, screws, wire nails etc complete as required, as per sample approved and direction of Engineer in charge including supply of all materials.	each
84-360-10	size; 2.45mx1.50mx0.30m	each
84-360-20	size; 1.80mx1.25mx0.30m	each
84-360-30	size; 1.20mx0.90mx0.25m	each
84-360-40	size; 0.90mx0.80mx0.25m	each
84-370	Supplying, fitting and connecting 15Amps/5Amps. 3 pin 250V grade combined socket outlet with switch (concealed/surface) without board.	each
84-370-10	15Amps. 3 pin 250V (surface).	each
84-370-20	15Amps. 3 pin 250V (concealed).	each
84-370-30	5Amps. 3 pin 250V (surface).	each
84-370-40	5Amps. 3 pin 250V (concealed).	each
84-410	Supplying, fitting and fixing of flourescent tube lights (1x40 W - 20 W), with superior quality choke, starter, holder etc with 18SWG sheet steel rust proof stove enamelled base with/without perspex cover to be fitted on wall/ceiling or suspended type with superior quality metal chain/ metal pipe including wiring with 2x1.5mm ² PVC insulated and sheathed wire with supply of all necessary materials etc. complete, as per direction of the Engineer in charge:	each
84-410-10	Single tube light(40W), 1.20 m long, without perspex cover.	each

ITEM DEFINITION REPORT

ItemCode	Item Description	Unit Meas.
84-410-20	Single tube(40W), 1.20m long, with perspex cover.	each
84-410-30	Single tube (20W), 0.60m long, without perspex cover	each
84-410-40	Single tube (20W), 0.60m long, with perspex cover.	each
84-420	Supplying, fitting and fixing of the approved quality florescent tube light (2x40W), 1.20 m long, with superior quality choke, starter, holder etc with 18SWG sheet steel rust proof stove enamelled base with/ without perspex cover to be fitted on wall/ ceiling or suspended type with superior quality metal chain/ metal pipe including wiring with 2x1.5mm ² PVC insulated and sheathed wire complete, as per sample approved and direction of Engineer in charge:	each
84-420-10	double tube light (2x40W), without perspex cover.	set
84-420-20	Double tube (2x40W), with perspex cover.	set
84-430	Supplying, fitting and fixing of the bracket light, with brass holder, 230mm brass bracket, 250 V, 60 W bulbs etc. complete, as per direction of Engineer in charge.	each
84-430-10	with 250mm dia EI Shade.	each
84-430-20	with 150mm dia white round glass globe with carrier	each
84-430-30	with fancy glass bracket holder with carrier	each
84-440	Supplying, fitting and fixing batten light fittings to be fixed on ceiling with brass batten holder etc complete with 250V, 60W lamp including supply of all materials as per direction of engineer in charge.	each
84-440-10	with 250mm dia EI Shade	each
84-440-20	with 200mm dia round glass globe.	each
84-440-30	with 150mm dia round glass globe.	each
84-440-40	with 250mm dia half round glass saucer.	each
84-450	Supplying, fitting, fixing and connecting of pendent light fittings for 60W/100W lamps, complete with brass pendent holder, twin flexible wire etc complete as required, as per sample approved and direction of Engineer in charge including supply of all materials.	each
84-450-10	with 250mm dia EI Shade.	each
84-450-20	with 200mm dia white round glass globe, with aluminium carrier and 13mm dia brass oxidized or chromium plated metal pipe of required length.	each
84-470	Supplying, fitting, fixing and connecting of the different items, including supplying of screws, nails, plastic tape etc. complete, as per direction:	each
84-470-10	standard quality 300 mm metal bulb shed	each

ITEM DEFINITION REPORT

ItemCode	Item Description	Unit Meas.
84-470-20	standard quality 230 mm metal bulb shed	each
84-470-30	200 mm glove shed for electric bulb	each
84-470-40	150 mm glove shed for electric bulb	each
84-470-50	100 mm glove shed for electric bulb	each
84-490	Supplying, fitting, fixing and connecting water tight bracket light, with brass holder, fancy and decorated glass shade with 'D'type glove reflector etc complete as required, as per sample approved and direction of Engineer in charge including supply of all materials.	each
84-500	Supplying, fitting and fixing of the 250 V, A.C. capacitor type ceiling fan, with regulator and other accessories etc. complete:	each
84-500-10	1400 mm sweep capacitor type : Millat/G.E.C./Singer or equivalent.	each
84-500-20	1200 mm sweep capacitor type : Millat/G.E.C./Singer or equivalent.	each
84-500-30	900 mm sweep capacitor type : Millat/G.E.C./Singer or equivalent.	each
84-500-40	1400mm sweep capacitor type : National(Tongi)/Jamuna/National King or equivalent.	each
84-500-50	1200mm sweep capacitor type : National(Tongi)/Jamuna/National King or equivalent.	each
84-500-60	900mm sweep capacitor type : National(Tongi)/Jamuna/National King or equivalent.	each
84-510	Supplying, fitting, fixing and connecting exhaust fan of approved quality with wall cover, providing erecting steel frame, louver shutter etc complete, as per sample approved and direction of Engineer in charge including supply of all materials.	each
84-510-10	size: 300mm	each
84-510-20	size: 400mm	each
84-510-30	size: 450mm	each
84-530	Supplying, fitting and connecting on prepared board single phase 250V grade miniature circuit breaker complete with thermal overcurrent and instantaneous electromagnetic short circuit release (made in UK/Germany/France/Switzerland/Sweden/Japan) of the following capacities as per direction of Engineer in charge.	each
84-530-10	5 Amps, MCB	each
84-530-20	10 Amps, MCB	each
84-530-30	15 Amps, MCB	each

ITEM DEFINITION REPORT

ItemCode	Item Description	Unit Meas.
84-530-40	20 Amps, MCB	each
84-530-50	30 Amps, MCB	each
84-530-60	60 Amps, MCB	each
84-700	Supplying and fitting of porcelain cutout, single phase with rewireable type fuse link fitted with aluminium casted enclosures including locking arrangement and connecting with the main switch board as per direction of Engineer in charge:	each
84-700-10	100 Amp. with box	each
84-700-20	60 Amp. with box	each
84-700-30	30 Amp. with box	each
84-700-40	15 Amp. with box	each
84-700-50	5 Amp. with box	each
84-730	Electrical grounding by 38mm dia G.I. pipe of 3.0 m length welded with 600mmx600mmx6mm M.S. plate including supplying and laying in position, 8 SWG copper wire as per drawing, concealed in 13mm dia PVC pipe digging pit of size 1.25mx1.25mx3.00m and back filling the same by 20kg salt and 12kg charcoal placed in suitably alternate layers and levelling the pit by locally available earth, watering, ramming etc. complete as per approved design, drawing and direction of Engineer in charge.	each
84-740	Manufacturing, supplying and erection of G.I. electric pole upto 6.0m long (4.5m being 75mm dia, and the balance 1.5m being 50mm dia fitted with 75mmx50mm reducer) including additional 1.2m long 38mm dia battered G.I. pipe fitted with 50mmx38mm reducer with 45 degree inclination at the top and the bottom end being welded with 300mmx300mmx6mm M.S. plate including fabrication, welding, supply & cost of all materials such as bamboo, jute rope, labours and other implements required for plumbing and erection in correct position, level & grade etc. complete as per PDB standard, and direction of Engineer in charge.	each
84-750	Dismantling and removal of existing over-head Conductor and earth-wire (DOG/ WASP/ RABBIT/ EARWIG/ COPPER No. 3/0, 2/0, 1/0, 1, 2, 3, 4, 7/8, 7/10, 7/0.136 and 7/0.166) including unbolting, untying, lowering the same at the ground level, recoiling or rewinding around a drum, packing the nuts, bolts and other deassembled materials including removal of stays, guys by digging out and dismantling concrete materials if necessary including supply of all tools and plants and handing over the same to depts. Store as per direction of the Engineer in charge. (All precautions shall have to be taken to ensure that the Conductor and other materials are not damaged).	m

ITEM DEFINITION REPORT

ItemCode	Item Description	Unit Meas.
84-760	Installation of over-head L.T. distribuion line including supply of 7/4.39 mm dia WASP (BRB, EASTERN or equivalent) insulated all aluminium standard Conductor as per BS-215 part 1:1970, 135:6485:1971, fitting of Conductor drum on to drum Jacks, lifting into snatch blocks, pretensioning, tensioning and sagging of Conductor, Lifting of Conductors to correct postion of insulators, making off at terminations binding into insulators, jumpering of the Conductors including supply of all other materials of PDB Standard and tools and plants necessary for the exection of the work as per direction of the Engineer in charge. (New Conductors shall be pretensioned for a period of not less than one hour at a tension equal to 1/3 of the breaking load of the Conductor as specified by the Engineer and shall be applied in his presence. Tensioning should be carried out using straining device and sagging should be carried out by using a sag-board or any other alternative method in a manner as approved by the Engineer in charge)	m
84-800	Providing all types of Mid-Span joint during the erection of new Conductor, (WASP), including cutting, cleaning and de-oxidising the Conductor ends, installing and making a mid-span joint as per PDB Standard and direction of the Engineer in charge.	each
84-810	Supplying, fitting & fixing of different size of 16 SWG galvanised metal gang box for MK switch including cost of all materials for	
84-810-10	1 gang box	each
84-810-20	2 gang box	each
84-810-30	3 gang box	each
84-820	Supplying, fitting, fixing & connecting of MK switch and MK socket of standard quality of different point	
84-820-10	MK Switch: 1 Gang	each
84-820-20	MK Switch: 2 Gang	each
84-820-30	MK Switch: 3 Gang	each
84-820-40	MK Socket: 2 pin: 5A	each
84-820-50	MK Socket: 3 pin: 15A	each
84-830	Supplying, fitting and fixing and connecting electronic dimmer of standard quality (Foreign made) for regulating fan speed.	each

ITEM DEFINITION REPORT

ItemCode	Item Description	Unit Meas.
90 . Dredging Work		
90-100	Basic dredging by operating dredger with necessary arrangement by Tug boat/Work boat disposing dredged earth upto 1.5 km, positioning the cutter of dredger at designed level by maintaining bathemetric prework and post work survey including the cost of mobilization and demobilization of dredger with houseboat by Tug boat/Work boat, fitting/fixing & maintenance of all necessary equipments, Supplying of necessary fuels & lubricants, shore pipes & floating pipes, anciliary dredging materials etc. complete as per direction of engineer in charge. (Not for BWDB Dredger)	cum
90-100-10	Basic Dredging work by 26" dredger.	cum
90-100-20	Basic Dredging work by 20" dredger.	cum
90-100-30	Basic Dredging work by 18" dredger.	cum
90-150	Extra Rate for booster pump beyond 1.5 km. (Not for BWDB Dredger)	cum/km
90-150-10	Extra Rate for booster pump beyond 1.5 km: 26" Dredger.	cum/km
90-150-20	Extra Rate for booster pump beyond 1.5 km: 20" Dredger.	cum/km
90-150-30	Extra Rate for booster pump beyond 1.5 km: 18" Dredger.	cum/km
90-200	Construction and dismantelling of temporary/permanent Shore pipe line at ground level laying on the ground or on 50 kg gunny bag where necessary, lifting manually/by tripod stand with chain pully, fitting/fixing shore pipe with nut-bolt & rubber gasket, levelling & dressing uneven ground where necessary, including the cost of necessary jute string, GI wire, etc. complete as per direction of engineer in charge. (Not for BWDB Dredger)	m
90-200-10	Construction and dismantelling of 26" Shore Pipe Line on Ground	m
90-200-20	Construction and dismantelling of 20" Shore Pipe Line on Ground	m
90-200-30	Construction and dismantelling of 18" Shore Pipe Line on Ground	m
90-220	Construction and dismantelling of temporary/permanent Shore pipe line laying on staging made by bullah of local wood (100 mm dia), lifting manually/by tripod stand with chain pully, fitting & fixing shore pipe with nut-bolt & rubber gasket, including the cost of necessary jute string, GI wire, etc. complete as per direction of engineer in charge. (Not for BWDB Dredger)	m
90-220-10	Construction and dismantelling of temporary/permanent 26" Shore pipe line laying on staging	m
90-220-20	Construction and dismantelling of temporary/permanent 20" Shore pipe line laying on staging	m
90-220-30	Construction and dismantelling of temporary/permanent 18" Shore pipe line laying on staging	m

ITEM DEFINITION REPORT

ItemCode	Item Description	Unit Meas.
90-240	Construction of mooring for 18" dredger, making anchorage both side of the dredger by driving hard wood bullah (125 mm dia, 1 m depth, 8 no of Bullah for two side achorage) tying with 14/16 BWG GI wire including fitting and fixing etc. cost of all materials as per direction of engineer in charge. (Not for BWDB Dredger)	each
90-250	Lifting shore pipe sinked into the mud below the ground level using tripod stand & chain hoist and cleaning with water, etc including the cost of all materials as per direction of engineer in charge. (Not for BWDB Dredger)	m
90-250-10	Lifting 26" shore pipe sinked into the mud below the ground level	m
90-250-20	Lifting 20" shore pipe sinked into the mud below the ground level	m
90-250-30	Lifting 18" shore pipe sinked into the mud below the ground level	m
90-270	Construction of outlet for dumping and disposal of water from disposal area by 300 mm dia and 12 m long PVC pipe,Placing 10 nos 125 kg sand-filled geobag at the outer end of pipe with polytheen sheet, etc. complete including the cost of all materials as per direction of engineering in charge. (Not for BWDB Dredger)	each
90-500	Filling ditch/pond/channel/khal etc or land development/improvement by borrowed/dredged earth from river bed (all kind of soil but excluding organic material) , carried by Bulkhead/cargo/boat or any other mean, loading and unloading/Disposing/placing the dredged materials in the designated area upto 1 km from river bank by bulkhead dredger including , maintaining slopes, levelling and dressing in layers upto finished level with all lifts & leads etc. all complete as per direction of the Engineer in charge.	cum/km
90-500-10	Bulkhead/cargo/boat or any other means: within 1 km along the river	cum/km
90-500-20	Bulkhead/cargo/boat or any other means: 2nd km and above.	cum/km
90-700	Basic dredging by operating dredger with necessary arrangment by Tug boat/Work boat disposing dredged earth upto 1.5 km, positioning the cutter of dredger at designed level by maintaining bathemetric prework and post work survey including the cost of mobilization and demobilization of dredger with houseboat by Tug boat/Work boat, fitting/fixing & maintenance of all necessary equipments, Supplying of necessary fuels & lubricants, shore pipes & floating pipes, anciliary dredging materials etc. complete as per direction of engineer in charge. (For BWDB Dredgers Only)	cum
90-700-10	Basic Dredging work by 26" dredger.	cum
90-700-20	Basic Dredging work by 20" dredger.	cum
90-700-30	Basic Dredging work by 18" dredger.	cum
90-750	Extra Rate for booster pump beyond 1.5 km (For BWDB Dredgers Only)	cum/km
90-750-10	Extra Rate for booster pump beyond 1.5 km: 26" Dredger	cum/km
90-750-20	Extra Rate for booster pump beyond 1.5 km: 20" Dredger	cum/km

ITEM DEFINITION REPORT

ItemCode	Item Description	Unit Meas.
90-750-30	Extra Rate for booster pump beyond 1.5 km: 18" Dredger	cum/km
90-800	Construction and dismantelling of temporary/permanent Shore pipe line at ground level laying on the ground or on 50 kg gunny bag where necessary, lifting manually/by tripod stand with chain pully, fitting/fixing shore pipe with nut-bolt & rubber gasket, levelling & dressing uneven ground where necessary, including the cost of necessary jute string, GI wire, etc. complete as per direction of engineer in charge. (For BWDB Dredgers Only)	m
90-800-10	Construction and dismantelling of 26" Shore Pipe Line on Ground	m
90-800-20	Construction and dismantelling of 20" Shore Pipe Line on Ground	m
90-800-30	Construction and dismantelling of 18" Shore Pipe Line on Ground	m
90-820	Construction and dismantelling of temporary/permanent Shore pipe line laying on staging made by bullah of local wood (100 mm dia), lifting manually/by tripod stand with chain pully, fitting & fixing shore pipe with nut-bolt & rubber gasket, including the cost of necessary jute string, GI wire, etc. complete as per direction of engineer in charge. (For BWDB Dredgers Only)	m
90-820-10	Construction and dismantelling of temporary/permanent 26" Shore pipe line laying on staging	m
90-820-20	Construction and dismantelling of temporary/permanent 20" Shore pipe line laying on staging	m
90-820-30	Construction and dismantelling of temporary/permanent 18" Shore pipe line laying on staging	m
90-840	Construction of mooring for 18" dredger, making anchorage both side of the dredger by driving hard wood bullah (125 mm dia, 1 m depth, 8 no of Bullah for two side achorage) tying with 14/16 BWG GI wire including fitting and fixing etc. cost of all materials as per direction of engineer in charge. (For BWDB Dredgers Only)	each
90-850	Lifting shore pipe sinked into the mud below the ground lebel using tripod stand & chain hoist and cleaning with water, etc including the cost of all materials as per direction of engineer in charge. (For BWDB Dredgers Only)	m
90-850-10	Lifting 26" shore pipe sinked into the mud below the ground lebel	m
90-850-20	Lifting 20" shore pipe sinked into the mud below the ground lebel	m
90-850-30	Lifting 18" shore pipe sinked into the mud below the ground lebel	m
90-870	Construction of outlet for dumping and disposal of water from disposal area by 300 mm dia and 12 m long PVC pipe,Placing 10 nos 125 kg sand-filled geobag at the outer end of pipe with polytheen sheet, etc. complete including the cost of all materials as per direction of engineering in charge. (For BWDB Dredgers Only)	each

SPECIFICATION OF MATERIALS

SPECIFICATION OF MATERIALS

1.0 Cement

1.1 Quality

All cement shall be ordinary Portland cement conforming to the requirements of BDS-EN-197-1-CEM1, 52.5 N or ASTM C150 Type 1 or BS 12, or equivalent. Special cement shall conform to the requirements laid down by the Engineer. The quality of ordinary Portland cement in general, should meet the following requirements.

1.2 Strength

The compressive strength and tensile strength of standard cubes and briquettes respectively shall not be less than as follows :

Days	Compressive strength, (N/mm ²)	Tensile strength (N/mm ²)
3	13	1.00
7	20	2.00
28	28	2.50

Setting Time :

Initial setting time : Shall not be more than 45 minutes

Final setting time : Shall not be more than 8 hours.

Fineness :

The ability to provide strength of a certain type of cement is checked by finding the fineness of that cement, because the fineness of cement is responsible for the rate of hydration and hence the rate of gain of strength and also the rate of evolution of heat.

If the cement is fine then greater is its cohesiveness, which is the property, required in the concrete because it gives compactness to the concrete. Usually cement loses 10% of its strength within one month of its manufacturing. For finding the fineness of Wet or Dry cement, following number sieve is recommended by ASTM.

Cement by wet process = # 300 sieve

Cement by dry process = # 200 sieve

Formula to calculate the percentage fineness of cement:

W1= Total weight of cement

W2= Weight of residue

Percentage of fineness= ((W1- W2)x 100)/W1

ASTM-STANDARD

For 100 gram sample: IF

Weight of w2 < 10 gram: Cement is fresh.

Weight of w2 > 10gram: Cement is not fresh.

OR

% age of fineness is > 90 %: Cement is fresh.

% age of fineness is <90 %: Cement is not fresh

Soundness :

In the soundness test a specimen of hardened cement paste is boiled for a fixed time so that any tendency to expand is speeded up and can be detected. Soundness means the ability to resist volume expansion. The cement when tested for soundness shall not have an expansion of more than 10 mm.

Unit weight : The unit weight of cement shall be 14.16 KN/m³.

Size of Bag : 50 kg

1.3 Delivery at site

Cement shall be delivered at work site in sound and property sealed jute/ paper bags, each plainly marked with manufacturer's name or registered mark. The cement shall be protected from the weather by tarpaulins or other approved covering during transit. The weight of individual bag containing cement shall be 50 kg and weight of all bags shall be uniform. The weight of cement shall be legibly marked on each bag. Bags in broken or damaged condition shall be rejected.

A certificate showing the place of manufacture and the results of standard tests carried out on the bulk supply from which the cement was extracted must accompany each consignment of cement delivered to the site.

1.4 Storage of cement

The contractor shall provide waterproof and well ventilated godowns at the specified or approved location at site, having a floor of wood or concrete raised at least 450 mm above the ground. The shed shall be large enough to store sufficient cement to ensure continuity of work and each consignment must be stacked separately to permit easy access for inspection.

Immediately upon arrival at site, cement shall be stored in the godowns with adequate provision to prevent absorption of moisture. All storage facilities shall be subject to approval by the Engineer and shall be such as to permit easy access for inspection and identification. The contractor shall use consignments in the order in which they are received. Cement delivered to the site in bags provided by the supplier or the manufacturer shall be stored in the bags until used in the works. Any cement in bags, which have been opened, shall be used immediately after opening. The cement shall not be stored in the godown for more than 4 (four) months or a lesser period as directed by the Engineer. After the exceedence of the period, any unused cement shall be removed from the site.

1.5 Testing of cement

The Engineer shall ask to carry out the sampling, inspection and testing of all cement, as he may consider necessary. Samples shall be taken as instructed from the site store, or from elsewhere on the works or from any places where cement is used for incorporation in the works. Cement may be rejected, discretion of the Engineer, if it fails to meet any of the requirements of the specifications. All testing shall be in accordance with ASTM designation C150 or equivalent.

2.0 Reinforcement

Reinforcement steel may be either plain or deformed or ribbed twisted. All reinforcing bars shall be mild steel, made from billet structural grade of Chittagong Steel Mills (CSM) and shall conform to the following specifications.

2.1 Plain and Deformed Bars

i.	Code of standard	ASTM A575, A615-Grade-40, A576
ii.	Chemical composition (%)	P (Phosphorus) = 0.05% (maximum)
		S (sulphur) = 0.05% (maximum)
iii.	Physical properties	Yield stress = 276 N/mm ² (minimum)
		Tensile stress = 414 N/mm ² (minimum)
		Percentage elongation = 20% minimum

iv. Standard Dimension and Weight

Bar diameter		Cross sectional area		Perimeter		Unit weight	
In	mm	in ²	mm ²	in	mm	LB/ft	kg./m
¼	6.35 6	0.05	28.27	0.79	18.85	0.167	0.249 0.22
5/16	7.94 8	0.07	50.26	0.98	25.13	0.261	0.370 0.395
3/8	9.525 10	0.11	78.54	1.18	31.42	0.376	0.56 0.62
½	12.7 12	0.20	113.10	1.57	37.70	0.668	0.99 0.89
5/8	15.875 16	0.31	201.06	1.96	50.27	1.043	1.56 1.58
¾	19.05 20	0.44	314.16	2.36	62.83	1.502	2.24 2.46
7/8	22.23 22	0.60	380.13	2.75	69.12	2.044	3.05 2.98
1	25.40 25	0.79	490.87	3.14	78.54	2.670	3.98 3.85
1½	28.65 28	1.00	615.75	3.54	87.96	3.400	5.06 4.83
1¼	31.75 32	1.27	804.25	3.99	100.53	4.303	6.22 6.31

V.	Dimensional Tolerance	Below 28.0 mm bar	±0.50 mm
		From 28.0 mm bar	±0.60 mm
VI.	Weight Tolerance	The difference between calculated weight and actual scaled weight shall be within ±3.5%	

vii. Requirements of deformation for Deformed Bar

- (a) Deformation shall be spaced along the bar at substantially uniform distances. The deformation on opposite sides of the bar shall be similar in size and shape.
- (b) The deformation shall be placed with respect to the axis of the bar so that the included angle is not less than 45° where the line of deformation forms and included angle with the axis of the bar of form 45° to 70°, inclusive, the deformations shall alternately reversed in direction from those on the opposite side. Where the line of deformation is over 70° a reversed in direction is not required. The average centre to centre or distance between deformation on each side of the bar shall not exceed seventeenths of the nominal diameter of the bar.
- (d) The overall length of deformation shall be such that the gap between the extreme ends of the deformation on opposite sides of the bar shall not exceed 12.5% of the nominal perimeter of the bar where the extreme ends terminate in a longitudinal ribs are involved the gap where more than two longitudinal ribs are involved the total width of all longitudinal ribs shall not exceed 25% of nominal perimeter of the bar; furthermore the summation of gaps shall not exceed 25% of the nominal diameter of the bar. The nominal perimeter of the bar shall be 3.14 ($\pi = 3.14$) times the nominal diameter.
- (e) The minimum height of deformation shall be not less than the following percentages of the nominal diameter of the bar.

Diameter of the M.S. Rod	Minimum height of Deformation in Percent of nominal Diameter of bar
10 mm dia.	4.0
12 mm dia.	4.0
16 mm dia.	4.5
20 mm dia.	5.0

- (f) The Spacing, Height and Gap of deformation shall conform to the requirements prescribed below:

Bar Size	Max. average spacing in mm	Min. average Height in mm	Max. gap in Chord 12.5% nominal perimeter
10 mm dia	6.7	0.38	3.5
12 mm dia	8.9	0.51	4.9
16 mm dia	11.1	0.71	6.1
20 mm dia	13.3	0.96	7.3
22 mm dia	15.5	1.11	8.5
25 mm dia	17.8	1.27	9.7
28 mm dia	20.1	1.42	10.9

2.2 Plain M.S. bar (made from scrap)

Plain M.S. bar made from scrap may be used in minor structures if specified. Minimum Yield Strength (f_y) for such bars shall be 248 N/mm². All other criteria shall be similar to those of M.S. bars from billets.

3.0 BRICKS

3.1 Uses

The standard specifies first class and jhama bricks for use in all type masonry works, course aggregate for concrete, filter material, road pavement works, manufacturing of brick blocks, brick mattressing work.

Second class brick may be used in preparing gabions and other temporary works.

3.2 Classification

I. 1st Class Bricks

They should be of uniform size and colour (typical red or buff) and thoroughly well burnt. They must emit clear metallic sound when struck with a hammer or another brick. They should be homogenous, well in texture, well shaped with sharp edges and even surfaces and free from flows, rainspot and cracks. A fractured surface shall show a uniform compact structure, free from holes, lumps or grills.

II. 2nd Class Bricks

Same as first class bricks but edges are not sharp.

III. Picked Jhama Bricks

Slightly over burnt uniformly textured, without cracks and spongy areas.

3.3 Dimension

Individual bricks shall be 240 mm x 120 mm x 70 mm size. The variation in dimension shall not be more than 5 mm in length, 2.5 mm in breadth and 1.5 mm in height.

3.4 Water Absorption

On being immersed in water for 1 (one) hours, the absorption shall not exceeded 15% of dry weight for 1st class bricks and 25% for 2nd class bricks.

Efflorescence: Slight to nil.

3.5 Minimum Crushing Strength

The minimum crushing strength shall be as follows:

1st class or jhama bricks	:	14.00 N/mm ² and above.
2nd class bricks	:	11.00 N/mm ² to 14.00 N/mm ² .

3.6 Unit Weight

Unit Weight of bricks shall be as follows:

1st class bricks	:	Not less than 1100 kg/m ³
Picked Jhama bricks	:	Not less than 1200 kg/m ³

4.0 Sand

4.1 Uses

The standard specifies sand to be used in plastering works, brick masonry works, manufacturing of cement concrete blocks, brick blocks, sand cement blocks, structural back filling works, foundation and well filling works. This excludes the specification of sand to be used as fine aggregates in Reinforced Cement Concrete.

4.2 Quality

Sand shall be non-plastic, non-saline, free from all silt, clay, roots and other organic materials.

4.3 Grading and F.M.

The grading of the various sized sand shall be as shown in the following table:

Grading Limits of Sand (% Passing)

Sieve Size	% Passing F.M. (1.50-2.80)	% Passing F.M. (1.00-1.50)	% Passing F.M. (0.80-1.00)	% Passing F.M. (0.50-0.80)
4.80 mm	95-100	100	100	100
2.40 mm	90-100	100	100	100
1.20 mm	70-95	97-100	100	100
600 micron	40-80	85-95	95-100	100
300 micron	10-50	50-70	70-80	80-90
150 micron	00-20	20-35	35-40	40-60

5.0 FINE AGGREGATE

5.1 Quality

Fine aggregate to be used in structural concrete shall be non-saline clean natural sand of specific gravity not less than 2.60. The sand shall have sharp angular grains of silica and grains shall be hard, dense and durable. It shall be free from injurious amount of clay lumps, lightweight materials or other deleterious of clay lumps, lightweight materials or other deleterious substances. The amount of silt, clay and fines should not exceed 5%. Fine aggregates shall be tested for organic impurities in accordance with ASTM Designation C40 or Equivalent.

5.2 Grading

The fine aggregate shall be tested according to ASTM Designation C136, conform to the following requirements, unless otherwise specified, and at fitness modulus between 1.5 and 2.5.

Sieve designation U.S. standard square mesh	Percent by weight passing
No. 4	95-100
No. 16	45-80
No. 50	10-30
No. 100	2-10
pan	3-7

6.0 COARSE AGGREGATE

6.1 Materials

Coarse aggregates shall be either brick chips (khoa) made from first class bricks/picked jhama bricks or shingles/ natural stones or crushed stone chips made from boulder/ gravel/ rock as specified.

6.2 Quality

The quality of aggregates, in general, shall conform to the specifications of parent material from which they will be made i.e. first class/ picked jhama bricks, shingles, boulder/ gravel/ rock. The pieces of aggregates shall be well shaped, angular without any thin or elongated particles. They shall be hard, dense, durable, clean and free from

adherent coatings. They should be non-reactive with cement and should not contain any harmful materials such as salts, coal residue, clay lumps, organic matter etc. The limit of deleterious materials such as clay, fine silt, fine dust etc. should not exceed % (one percent).

6.3 Grading

Coarse aggregate shall be tested according to ASTM Designation C136 or equivalent. Gradations for 50 mm, 40 mm, 25 mm and 20 mm size aggregates, unless otherwise specified, shall conform to the following requirements.

Sieve designation U.S. Standard square mesh	Percent passing by weight			
	50 mm	40 mm	25 mm	20 mm
63.50 mm (2.5'')	100	-	-	-
55.80 mm (2.0'')	95-100	100	-	-
38.10 mm (1.5'')	-	95-100	100	-
25.40 mm (1.0'')	35-70	-	95-100	-
19.05 mm (¾'')	-	35-70	-	100
12.70 mm (½'')	10-30	-	25-60	90-100
9.52 mm (3/8'')	-	10-30	-	40-70
No. 4 (3/16'')	0-5	0-5	0-10	0-15
No. 8 (1/8'')	-	-	0-5	0-5

7.0 BITUMEN

The bitumen shall be homogenous, free from water and shall not foam when heating to 180°C. It shall be packed in brand new non-leakable steel drums minimum 0.63 mm thick and securely sealed. Gross weight of each drum shall not exceed 180 kg. The quality of bitumen should meet the following requirement.

Penetration	=	within 80 to 100
Specific gravity	=	within 1.00 to 1.05 (at 25°C)
Softening point	=	within 40°C to 54°C
Loss on heating	=	not to exceed 0.75 %
Flash point	=	not less than 230°C
Solubility	=	not less than 99.5 %

All tests shall be carried out in accordance with the standard test procedures adopted by RHD.

8.0 PVC WATER STOP

8.1 Scope

This standard specifies flexible poly vinyl chloride (PVC) water stop at the contraction and expansion joints of hydraulic structures.

8.2 Types

In general PVC water stop may be two or three bulb dump bell type or corrugated type as shown in figure.

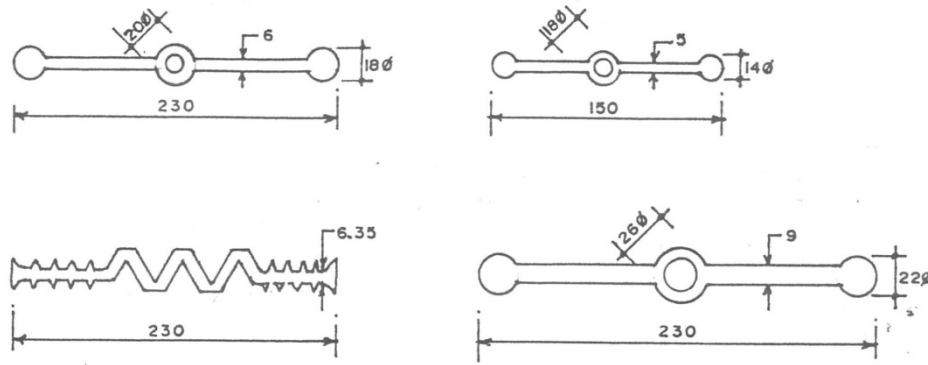

All dimensions are in mm

8.3 Dimension

The dimension of water stop shall be as shown in the figure.

8.4 Quality

- Water stop shall be of high grade of PVC containing no filler or reclaimed or scrap material. PVC shall comply with the requirements of BS 2571 for PVC type A, Class-1.
- The surface of water stop shall be free from defects such as harmful cracks, crazing and the like when visually inspected.
- The quality of water stops shall comply with the requirements :

Specific Gravity	:	1.30 (maximum)
Hardness	:	80 (minimum)
Tensile strength	:	13.80 N/mm ² (minimum)
Elongation	:	225 % (minimum)

9.0 STONE/ BOULDER

Stone / Boulder shall comply with the following requirements :

- The material shall not be polluted and shall be free from objectionable quantities of dirt, sand, rock dust and elongated or flaky stones.
- The material shall be free from cracks and veins, which could lead to breakage during loading, unloading and dumping.
- The dimension of single rock shall not differ notably in size. The ratio between the smallest and largest dimension of single stone shall generally be not less than 0.4.
- The aggregate impact value shall not exceed the 30% limit as per BS 812 : part-3, Chapter-6.
- The bulk specific gravity shall have a minimum value of 2600 kg/m³ as per BS 812, Part-2, Chapter-6.
- The weighted average loss of material in the Sodium Sulphate Soundness Test shall not be more than 10% by weight as per ASTM C88.

- g) The percentage of wear as per loss Angeles Test shall not be more than 40 as per ASTM C535.
- h) The rock material shall comply with the grading requirements as specified for concerned work.
- i) Water absorption of stone/boulder shall not exceed 6% (BS 812).
- j) Minimum compressive strength : 100 N/mm² (ASTM C 170-50).

Grading Tests at Point of Delivery

- Testing at the agreed point of delivery (stockpile yard) shall take place at the supplier's expenses.
- The gradation of materials stock piled at the yard shall be tested at least one time for each 500t of delivery.
- Samples for determination of weight gradation shall contain at least 100 individual stones/ rocks. The samples shall be taken by random selection from each specified gradation to obtain representative samples, and shall confirm to the grading as specified.
- Only stone/rock with a factor not exceeding 2.5 between the longest and shortest dimension of the rock shall be allowed in the delivery.
- In case of non-compliance with the specified gradation range more tests may need to be performed.
- In case the additional tests show non-compliance the whole or part of the rock delivery may be rejected

10.0 STEEL SHEET PILE

10.1 Uses

This standard specifies steel sheet piles for use in cut-off wall of hydraulic structures except otherwise mentioned in the drawing. Specified steel sheet piles of cold dawn steel sheet are excluded from this standard.

10.2 Quality

- a) Steel sheet piles shall not show any harmful defects under use. It shall be straight and out end surfaces shall be flat, for all practical purposes. It shall be adequately engaged with adjacent piles during driving provided that they can be disengaged for extracting.
- b) Joints of steel sheet piles shall be watertight provided their structure does not obstruct driving and extraction.

c) Steel sheet piles shall be rolled from structural carbon steel and shall have the following chemical and mechanical properties:

- (i) Chemical Properties
 Phosphorus : 0.04% (maximum)
 Sulphur : 0.04% (maximum)
- (ii) Mechanical Properties
 Tensile strength : 490 N/mm²
 Yield strength : 296 N/mm²
 Elongation : 15% (minimum)

10.3 Type

Steel sheet piles shall be classified in accordance with the cross sectional shapes given below:

U-Type	Roughly U-shaped with joints of piles when driven located on the neutral axis of the piling work.
Straight/ Flat Type	Flat shaped close to straight line with high resistance to tensile force.

10.4 Size, Weight and Section Properties

- (a) Length of steel sheet piles shall be in terms of whole numbers of meters of standard lengths and shall be measured in divisions of 500 mm. There shall be one handling hole of 25mm to 60mm diameter, center of which is to be located 100mm to 300mm from one end.
- (b) Sheet pile wall having minimum weight per unit wall area against the desired section modulus per unit area shall be preferred.
- (c) Size and weight of U-Type steel sheet piles are as follows:

Width (w)	Height (h)	Thickness	Cross Sectional Area	Weight		Elastic Section Modulus	Moment of Inertia	Coating Area (both sides per pile)
				Per Pile	Per Wall			
mm	mm	mm	cm ² /m	kg/m	kg/m	cm ³ /m	cm ⁴ /m	m ² /m
400	85	8	-	35.5	88.88	529	4500	-
400	100	10.5	152.9	48	120	874	8,740	1.33
400	125	13	191.1	60	150	1,340	16,800	1.44
400	150	13.1	186	58.4	146	1,520	22,800	1.44
600	180	13.4	173.2	81.6	136	1,800	32,400	1.9
600	130	10.3	131.2	61.8	103	1,000	13,000	1.77
400	170	15.5	242	76.1	190	2,270	38,600	1.61
600	210	18	225.5	106	177	2,700	56,700	1.99
500	225	27.6	305.7	120	240	3,820	86,000	1.82

(d) Tolerance in Thickness of Sheet pile : $\pm 0.50\text{mm}$

(e) Size and weight of Straight/ flat type steel sheet pile

Width	400 mm
Height	44.50 mm
Thickness	9.50 mm to 12.70 mm
Weight per meter of pile	54.20 kg. to 60.80 kg.
Section modulus per pile	47.80 cm ³ to 48.30 cm ³

11.0 Ferro-cement Sheet Pile

Ferro-cement sheet pile shall be used only as cut-off pile. The width of each pile shall be limited to 650 mm and the depth of the cut-off shall however not exceeds 2.00 m and shall be provided for small hydraulic structures as provided in the drawing.

Manufacturing:

- a) Ferro-cement sheet pile shall be pre-cast at the location of the work as per design and drawing.
- b) It shall be made of sand-cement mortar with leanest mix proportion of 1:2 (cement : sand). Cement to be used shall be in accordance with clause 802 and F.M. of sand shall be ≥ 2.0 . Sand-cement mortar shall develop a 28 days compressive cylinder strength of minimum 20.0 N/mm².
- c) M.S. reinforcement of minimum yield strength 276 N/mm² shall be used.
- d) Form works to be used shall be made of steel so as to achieve smooth finished concrete surface.

12.0 BULLAH PILE

- a) Bullah pile shall be Sonali, Gul, Tetul, Sal, Sundari or Gazari. It should be matured, straight and free from large or loose knots, cracks and other defects.
- b) The diameter of bullah at its tip shall not be less than 100mm and at butt end as specified. The average diameter of bullah shall be measured at 1/3rd length from its butt end without bark.
- c) Bullah pile to be used as foundation pile placed above water table or within the fluctuation zone of water table shall be treated with a water repellent preservative creosote for a minimum period of 24 hours in accordance with BS 5268, part-5, 1977.
- d) A straight line drawn from the centre of the butt to the centre of the tip shall be contained entirely within the pile.

13.0 Geotextile and Geobag

- Geotextile used as filter.
- Geotextile used in Geobag.
- Geotextile shall be manufactured from 100 % polypropylene and fiber shall be needle punched. Unit Weight of Geotextile is 855 kg/m³.

- Brand name and grade of all geotextiles shall be clearly and uniformly marked on the upper face. The marking shall take the form of an indelible repeat roll imprint at the edge of each geotextile roll recurring at least every 1.5 m.
- Geo-textile bags, filled with sand 95% retain on #200 sieve.
- Geobag must withstand loads resulting from filling, handling, transporting, dumping and hydrodynamic forces.
- It is very important that the sand does not leak out over time.
- Each batch of geobags delivered at site shall be packed in standard numbers and marked with labels that identify the (i) brand and grade, (ii) production lot number and date of production of geotextile, (iii) number of bags, (iv) size of bags, and (v) name and signature of the quality control person certifying the compliance of all bags per bale
- Each bag shall be double stitched along all edges except for the opening at the top of each bag which shall be closed after filling. The minimum tensile strength of the seam shall be not less than 90% of the tensile strength of the geotextile.
- After filling, the opening of geobag shall be closed by double stitched with corner stitch.
- The number of stitch per inch should not be less than 5. The stitch shall be double thread chain type.
- The two lines of stitches shall be within 5 mm distance with a margin of 2 cm from the edge of the geotextile to the centerlines between the two seams.
- The thread used for the seam should be of same material as the geotextile (e.g. polypropylene or polyester).
- At the bottom end of each seam (at the folded site) the stitch shall be locked either by stitching one time back and forth for a length of minimum 2.5 cm from the end of the bag, or by joining the ends of the two threads e.g. by gluing, welding, knotting or other appropriate methods.
- The bags shall be stored under cover, well sheltered from direct sunlight and to prevent the ingress of dust or mud. They shall be protected from damage by insects or rodents.

- Average Area Coverage of Geobag after sand filling :

Weight of Geobag	Approximate Area covered by geobag after sand filling (sqm)
80 kg	0.32 sqm
125 kg	0.50 sqm
175kg	0.70 sqm
250kg	1.00 sqm

Properties of Geotextiles

Properties	Test Standard	Test values
Opening size O_{90}	EN ISO 12956	≥ 0.06 and ≤ 0.08 mm
Mass per unit area	BS EN 965	≥ 400 g/m ²
CBR Puncture Resistance	EN ISO 12236	≥ 4000 N
Tensile Strength (machine direction-MD or cross machine direction-CMD)	EN ISO 10319	≥ 20.0 KN/m
Elongation at maximum force-MD	EN ISO 10319	$\geq 60\%$ and $\leq 100\%$
Elongation at maximum force-CMD	EN ISO 10319	$\geq 40\%$ and $\leq 100\%$
Permeability (velocity index for a head loss of 50 mm – V_{H50})	EN ISO 11058	$\geq 2 \cdot 10^{-3}$ m/s
Minimum thickness	EN ISO 9863	≥ 3.00 mm
Abrasion	Following RPG of BAW, Germany, O_{90} according EN ISO 12956 and thickness according BS EN 9641	After test: tensile strength $\geq 75\%$ of specified tensile strength, thickness $\geq 75\%$ of original value, $O_{90} \leq 0.09^{*2}$
UV Resistance	ASTM D4355	$\geq 70\%$ of original tensile strength before exposure

14.0 **CC Block**

- Pre-cast concrete blocks shall be made as per dimensions shown on the drawings.
- The materials and workmanship shall comply with the standard specification in all respects.
- Pre-cast concrete blocks (cc blocks) shall be made from concrete with the compressive strength as shown in the drawing, such as 9 N/mm², 10.5 N/mm², 15 N/mm², 16 N/mm².
- The blocks shall comply with the percentages of the different sizes as shown on the drawings. A size wise schedule of all blocks shall be prepared before execution of the work.
- Each block shall be marked with a serial number and the date of casting.
- Marking shall be engraved on the block whilst the concrete is still "green". Marking by paint is not acceptable.
- A register (officially issued) shall be used to maintain the number, date of casting, date and location of placing/dumping of each block at site and available at all times for inspection.
- Blocks shall not be stockpiled until they have been cured.
- Blocks, which are damaged during transport, stockpiling or handling, shall be rejected and removed from the site.

Quality Control of CC Block

- During the production of CC blocks quality tests shall be performed in accordance with the DIN 1045 or BS.
- Compressive Strength of CC Block may be determined by either cube test or cylinder test for each 100cum of concrete poured. 6 (six) specimen shall be prepared in each set.
- Size of cubes shall be 20x20x20cm. Size of cylinder shall be of 150mm diameter and 300mm height.
- In case more than one batching plant is used, then one set of six test specimens is to be produced for each plant on every working day.
- Three samples of each set shall be tested after 7 days and other three sets shall be tested after 28 days of its production.
- The compressive strength shall at least correspond to the minimum values stipulated in design.

- Compressive strength may also be determined by cutting core from CC Block at any time.

Production of CC Block

- Formwork and moulds shall ensure the designed shapes and sizes of block. They shall be of steel.
- Formwork and moulds must be water tight during placing of concrete.
- The moulds shall be sufficiently tight fitting to prevent grout losses and sufficiently rigid to withstand the effects of pouring and vibrating during placing the concrete without distorting and capable of releasing the hardened concrete blocks without causing damages to the blocks.
- The ingredients of concrete such as cement, fine aggregates, coarse aggregates and water shall be measured correctly for each batch of mixing. In case of volumetric batching the bulking of aggregates must be accounted.
- Hand mixing of concrete is prohibited. Batching plants shall be used for mixing concrete.
- Mixing of concrete shall be done thoroughly to ensure that concrete of uniform color and consistency is obtained.
- Concrete shall be transported from the place of mixing to the place of final deposition as quickly as possible. The methods adopted should ensure that concrete is placed in position within Initial Setting Time of cement i.e 45 minutes.
- Re-handling shall not occur at any time.
- Un-used concrete of one day shall not be used on the next day.
- Platform as per specification shall be constructed for casting of CC block.
- Concrete shall be placed directly in its final position avoiding segregation.
- Concrete should be placed gently at its position and not thrown from a height.
- Before placing concrete the formwork and moulds shall be cleaned and well wetted.
- Compaction of concrete shall be properly done to secure maximum density and strength.
- Compaction of concrete shall be done immediately after placing of concrete.

Water in the Production of CC Block

- Water used in concreting shall be fit for drinking purpose.
- The water used for concrete mixing, curing, or other designated applications shall be fresh water, clean and free from oil, salt acid, alkali, sugar, vegetable or any other substance injurious to the finished product.
- The water shall meet the requirements of the Standards, in particular DIN 4030 or BS 3148.
- The water to cement ratio shall be within 0.45 to 0.55 by weight. This ration shall strictly be maintained.

Curing of CC Block

- Concrete shall be protected from the effects of sunshine, dry wind, running water or mechanical damage for a continuous period, until the concrete has reached at least three quarters of its 28 day strength, but not less than 10 days.
- Curing shall begin as soon as the concrete is sufficiently hard and shall be continued for 21 days.
- Curing methods may be by spraying water to the concrete, or by covering the concrete surface with a layer of gunny bags, canvas, hessian, straw or similar absorbent materials which is to be kept constantly wet.
- In short, concrete surface shall be always wet, without any break, for 21 days.

15.0 **Underwater Dumping**

- Placing of underwater apron materials require a considerably higher skill, equipment demand and standard of control.
- Sufficient number of pontoons or flat-top barges for the timely completion of works shall be arranged at site.
- Total material required to be dumped in a particular stretch shall be stacked on flood plain/bank before start of dumping in the reach.
- CC blocks/boulders/sand filled geobags/apron material from stack-yard will be transported to the dumping barges/pontoons by engine boats or self-propelled barges.
- No dumping shall be allowed without properly positioned and anchored dumping pontoon/flat-top barge.

- Any strip of underwater protection from the river-side edge of the falling apron to the edge of shallow water (Average Low Water or SAL) must be completed in a day's work.
- The quantity of material to be dumped per unit length of bank shall be stacked along the dumping edge of the pontoon/ barge and dumped at proper position as directed by the control through total station on the bank.
- Dumping aid shall not have any sharp corners or edges or any other features that could damage the bags or reduce the properties of the bags making them unsuitable as protective launching element.
- Immediately after mobilization of equipment, preparation for anchoring of pontoons should start. Anchor points on flood plain should be free from flooding and risk against wave erosion. Sufficiently strong anchors, piles, bollards or winches shall be used and safely installed.
- Anchor points in the river may consist of anchor pontoons equipped with winches temporarily positioned at site to hold and move the dumping pontoons during dumping of bags. Alternatively, dumping pontoons can be directly anchored into the riverbed. Standard anchors can be used, such as stockless anchors having a holding power of about 3 to 5 times the own weight. In selecting type of anchors, flow velocity, bed material etc shall be taken into consideration.
- Underwater dumping shall be complete before 30th April.
- No construction work on under-water apron shall start if the flow velocity is 1.5 m/sec or higher. This can be relaxed only when emergency protection or repair of protection work is needed.
- Survey boat equipped with sonar scanner and divers for direct underwater inspection shall be used throughout the construction period.

16.0 **Machinery and equipment needed for River Bank Protection work**

- Flat top barges
- Pontoons
- Tug boats (400 HP)
- Drum mooring winches with ropes and anchors
- Crane (40-ton capacity)
- Topographic and bathymetric survey teams with equipment
- Diver team
- Sewing machines (if geobag is used as apron material)
- Generators
- Laboratory for sand and concrete strength testing
- Motorized country boat
- Concrete mixers
- Excavator
- Compaction Equipment

17.0 Sand-Cement Gunny Bag /Geobag

- Shall be used for precautionary work.
- Water Cement ration is 0.50.
- Minimum curing is 7 days.
- Dumping or placing shall be done after curing.
- Approximate thickness of one layer of Sand-Cement filled Gunny Bag :

Size	Approximate thickness
75kg	0.14m.
50kg	0.10m

18.0 Geotube

- Material of Geotube shall be Geotextile. Specification of Geotextile shall be as stated in Article 13.0.
- Geotube shall be filled hydraulically with sand.
- 95% sand shall retain on # 200 sieve.
- Height of Geotube : Approximately 70% of Dia after sand fill.
- Length of Geotube : Approximately max 30 m or as per design.

CONVERSION TABLE

1mm = 0.3937 inch. 1m = 3.281 ft. = 1.094 yd. 1km = 0.6214 mile.	1 inch = 25.4mm 1 ft. = 0.3048 ft. 1 yd. = 0.9144 m. 1mile = 1.609 km.
1 mm ² = 0.00155 in ² 1 m ² = 10.76 ft. ² 1 m ² = 1.196 yd. ² 1 hectare = 2.471 acre = 1000 m ²	1 in ² = 645.20 mm ² 1 ft ² = 0.0929 m ² 1 yd ² = 0.8361 m ² 1 Acre = 0.7646 m ²
1 mm ³ = 0.00006102 in ³ 1 m ³ = 35.31 ft ³ = 1.301 yd ³	1 in ³ = 16390 mm ³ 1 ft ³ = 0.02832 m ³ 1 yd ³ = 0.7646 m ³

Force:	
1 N = 0.2248 lb. = 0.102 kg. 1kg = 2.205 lb. 1KN = 0.1004 Ton = 102.0 kg = 0.102 Tonne 1 Tonne = 1000 kg = 0.9842 Ton = 9.807 KN 1 Quintal = 1.9684 Cwt	1 lb = 0.4536 kg. 1 Ton = 9.964 KN. = 1016 kg. = 1.016 Tonne 1 Cwt. = 112lbs. = 50.80 kg. = 0.508 Quintal

Force Per Unit Length:	
1 N/m = 0.06852 lb/ft = 0.1020 kg /m 1 lb/ft = 14.59 N/m = 1.488 kg/m	1 KN/m = 0.0306 Ton/ft. = 0.102 Tonne/m 1 Ton/ft = 32.69 KN/m = 3.333 Tonne/m

Force per unit area:	
1 N/mm ² = 145.0 lb/in ² = 10.20 kg./cm ³ 1 lb/in ² = 0.006895 N/mm ² = 0.0703 kg./cm ² 1 N/m ² = 0.02089 lb/in ² = 0.102 kg/m ² = 1 Pa	1 Ton/in ² = 15.44 N/mm ² = 157.5 kg/cm ² 1 N/mm ² = 9.324 Ton/ft ² 1 Pa = 1 N/m ² 1 MPa = 1 N/mm ²

Force per unit volume:	
1 N/m ³ = 0.006366 lb./ft. ³ 1 lb/ft ³ = 157.1 N/m ³ = 16.02 kg/m ³ 1 KN/m ³ = 0.003684 lb/in ³ = 0.102Tonne/m ³	1 lb./in ³ = 271.4 KN/m ³ = 27.68 Tonne/m ³ 1 KN/m ³ = 6.366 lb/ft ³ 1 Ton/ ft. ³ = 351.9 KN/m ³ = 35.88 Tonne/m ³

Fluid Capacity :	
1 litre = 0.22 Imperial gallon = 0.2642 US gallon	1 Imperial gallon = 4.546 litre = 1.201 US gallon

Power : 1 HP = 0.7457 KW	1 KW = 1.341 HP
---------------------------------	-----------------

LIST OF ABBREVIATIONS

	Abbreviations		Abbreviations
km	Kilometer	p/km	per kilometre
m	meter	p/set	per set
mm	millimeter	P phour	pump per hour
ft	foot	P twell	per tube well
in	inch	Pld cum	per lead per cubic metre
yd	yard	Plt cum	per lift per cubic metre
kg	Kilogram	pmt/m	per metric ton per metre
gm	gram	pmt/km	per metric ton per kilometre
lbs	Pounds	pcum/m	per cubic metre per metre
Cwt	Hundred weight	cum/km	per cubic metre per kilometre
Ltr	Litre	p%0/m	Per 1000 number per metre
N	Newton	p%0/km	Per 1000 number per kilometre
KN	Kilo newton	F.M	Fineness modulus
Sq	square	C.P	Chromium plate
m	metre	PVC	Poly vinyl chloride
cum	cubic metre	UV	Ultra violet
pnt	point	C.I.	Corrugated Iron
Nos.	numbers	CIMH	Cast iron man hole
G.L	Ground level	day	8 hours day
B.M.	Bench mark	SWG	Standard wire gauge
M.S.	Mild steel	BWG	British wire gauge
G.I	Galvanized Iron		

UNIT WEIGHT OF VARIOUS MATERIALS

Sl. No.	Materials	Unit weight
1.	Cement	50 kg per bag/1440 kg per cum
2.	Sand, Dry, clean	1450 to 1600 kg per cum
3.	Earth	1600 to 2000 kg per cum
4.	Iron (wrought)	7800 kg per cum
5.	Cast Iron	7222 kg per cum
6.	Teak wood	682 kg per cum
7.	Sal wood	995 kg per cum
8.	Water	1000 kg per cum
9.	Lime	674 kg per cum
10.	Surki	1010 kg per cum
11.	Tiles	128 kg per sqm
12.	Brick	3.64 kg per No
13.	Asphalt	2300 kg per cum
14.	C.I. Sheet (Depending on Gauges) Cast Iron	102 kg per bundle
15.	16 BWG sheet	11.50 kg per sqm
16.	Corrugated asbestos sheet	16 kg per sqm
17.	Coal	800 to 900 kg per cum
18.	Cement Plaster	2080 kg per cum
19.	Wire barbed Ordinary for fencing	0.13 kg per meter
20.	Sand stone	2240 to 2400 kg per cum
21.	Shingles	1444 kg per cum
22.	Petrol	642 kg per cum
23.	Paints ready mixed with Zink	2400 kg per cum
24.	Lead	11350 kg per cum
25.	Brick Masonry	1800 to 1950 kg per cum
26.	Cement Concrete	2000 to 2400 kg per cum

STANDARD ANGLES OF COMMON USE

Sl. No.	Size in mm	Thickness (t) in mm	Weight per metre length in kg	Sectional Area in cm ²
1.	20x20	3.00	0.90	1.12
		4.00	1.10	1.45
2.	25x25	3.00	1.10	1.41
		4.00	1.40	1.84
		5.00	1.80	2.25
3.	30x30	3.00	1.40	1.73
		4.00	1.80	2.26
		5.00	2.20	2.77
4.	35x35	3.00	1.60	2.03
		4.00	2.10	2.66
		5.00	2.60	3.27
		6.00	3.00	3.86
5.	40x40	3.00	1.80	2.34
		4.00	2.40	3.07
		5.00	3.00	3.78
		6.00	3.50	4.47
6.	45x45	3.00	2.10	2.64
		4.00	2.70	3.47
		5.00	3.40	4.28
		6.00	4.00	5.07
7.	50x50	3.00	2.30	2.95
		4.00	3.00	3.88
		5.00	3.80	4.79
		6.00	4.50	5.68
8.	55x55	5.00	4.10	5.27
		6.00	4.90	6.26
		8.00	6.40	8.18
		10.00	7.90	10.02
9.	60x60	5.00	4.50	5.75
		6.00	5.40	6.84
		8.00	7.00	8.96
		10.00	8.60	11.00
10.	65x65	5.00	4.90	6.25
		6.00	5.80	7.44
		8.00	7.70	9.76
		10.00	9.40	12.00
11.	70x70	5.00	5.30	6.77
		6.00	6.30	8.06
		8.00	8.30	10.38
		10.00	10.20	13.02

Sl. No.	Size in mm	Thickness (t) in mm	Weight per metre length in kg	Sectional Area in cm ²
12.	75x75	5.00	5.70	7.27
		6.00	6.80	8.66
		8.00	6.90	11.38
		10.00	11.00	14.02
13.	80x80	6.00	7.30	9.29
		8.00	9.60	12.21
		10.00	11.80	15.05
		12.00	14.00	17.81
14.	90x90	6.00	8.20	10.47
		8.00	10.80	13.79
		10.00	13.40	17.03
		12.00	15.80	20.19
15.	100x100	6.00	9.20	11.67
		8.00	12.10	15.39
		10.00	14.90	19.03
		12.00	17.70	22.59
16.	110x110	8.00	13.40	17.02
		10.00	16.50	21.06
		12.00	19.60	25.02
		15.00	24.20	30.81
17.	130x130	8.00	15.90	20.22
		10.00	19.70	25.06
		12.00	23.40	29.82
		15.00	28.90	36.81
18.	150x150	10.00	22.80	19.03
		12.00	27.20	34.59
		15.00	33.80	42.78
		18.00	39.90	50.79
19.	200x200	12.00	36.60	46.61
		15.00	45.40	57.80
		18.00	54.00	68.81
		25.00	73.60	93.80